



Mercedes-Benz

The new C-Class

“Refinement, design, safety... the new C-Class
is a thoroughbred Mercedes. See for yourself”

Dr Dieter Zetsche

Contents

The new C-Class	12	My new C-Class	64
Agility	14	Design and equipment lines	66
Diesel engines	16	CLASSIC	68
Petrol engines	18	ELEGANCE	74
Transmissions	22	AVANTGARDE	80
Suspension	24	AMG sports package	88
4MATIC	26	Equipment	94
Comfort	30	Standard equipment	96
Interior	30	Light-alloy wheels	98
Cockpit	32	Audio and communication systems	102
Seat comfort	34	Optional extras	103
COMAND APS	36	Standard equipment/optional extras for Estate	106
Ride comfort	38	designo	108
Load compartment	40	Genuine accessories	112
Safety	44	Colours and materials	116
PRO-SAFE™	44	Paintwork	118
AMG	56	Upholstery and leather	120
		Trim elements	122
		Combination options	123
		Technical characteristics	124
		Saloon	124
		Estate	128
		Service	132

Get a new feel for the road

The new C-Class. Agility and effortless superiority

Grey asphalt may not be one of life's most inspiring sights, but for over 120 years now, our vehicles have shown that it can give drivers a lot of fun. Reason enough, we thought, to go a step further and offer a new interpretation of driving pleasure. The result is the new C-Class. Available as a Saloon or an Estate, it allows you to experience the road as never before. Few cars can compete with its ability to adjust so many facets of its character – from the interior to the drive technology – so quickly and precisely in response to external conditions and your own particular needs.

The advanced technology for the new model includes the standard-fit AGILITY CONTROL package with selective

damping as well as the optional dynamic handling package with sports mode which allows you to adjust the vehicle's handling at the touch of a button. A wide range of engines (including a number of uprated units) means that the C-Class can be specified to meet just about any performance requirements while the arrival of the new Estate offers the ideal combination of functionality and flexibility. Both models feature fine materials and a new design, creating an even more compelling interior ambience (whether this reflects a more sports-oriented character or a particular emphasis on comfort is entirely up to you). As you will see, in terms of its external appearance, too, the new C-Class has, quite literally, several faces.



A mark of personality

The design of the C-Class AVANTGARDE

The completely new design of the exterior and interior has created a larger, wider and more spacious C-Class which is available with an impressive new range of paint finishes and upholstery patterns. What's more, you can choose which aspect of your C-Class you would like to highlight. The AVANTGARDE design and equipment line emphasises the car's sporty side. The dominant star in the radiator grille makes a powerful statement, while the chrome band which runs right around the body accentuates the taut lines of the new C-Class.

A sure sign of style

The design of the C-Class ELEGANCE

The ELEGANCE design and equipment line brings the refinement and comfort of the C-Class to the fore. The characteristic star features as a free-standing element on the bonnet and the different chrome trim elements around the vehicle give the new C-Class a particularly impressive presence. Tone-in-tone colour schemes contribute to the warm, pleasant atmosphere of the interior. Convex, chromed badges on the front wings designate the ELEGANCE and AVANTGARDE design and equipment lines. Naturally, the timeless appeal of the CLASSIC design and equipment line is also available for the new C-Class.









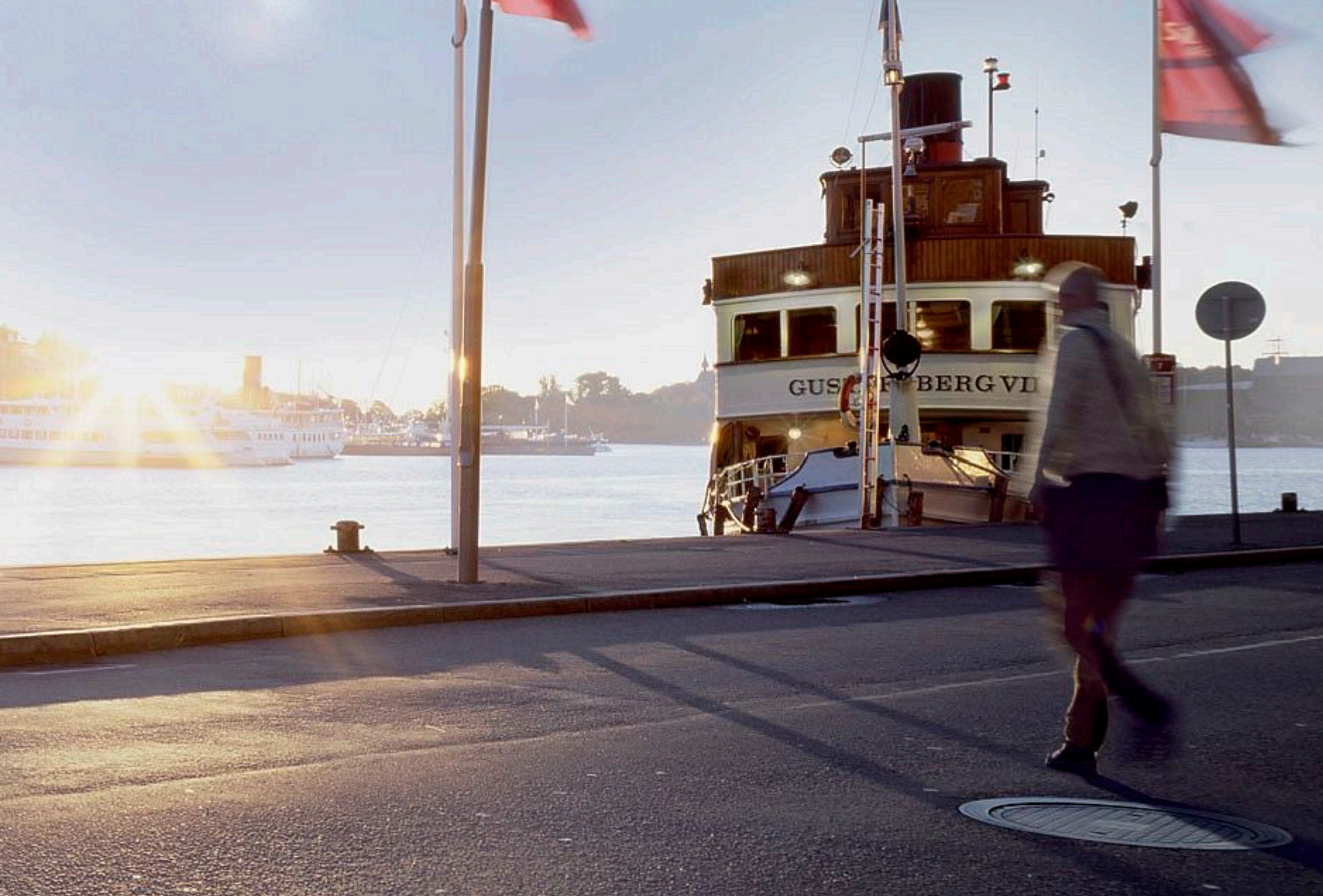

GUS F. BERG VI





The new C-Class



Your most enjoyable drive ever. Each time you get in

An agile look - right down to the last centimetre

The new C-Class is a pleasure to behold: its taut lines lend it an air of effortless superiority while the wide radiator grille and distinctive rear section announce a vehicle with a real presence and a dynamic personality. But these compelling looks are only part of the story.

The new C-Class is equipped with many innovative technical features which deliver a driving experience that is unique in this class. Think ease and confidence. Among the highlights is the new AGILITY CONTROL package. This comprises AGILITY CONTROL suspension with a selective damping system which automatically adjusts the suspension set-up in accordance with the condition of the road -

giving you a consistently high level of driving enjoyment. As an option, you can specify the dynamic handling package with sports mode which allows you to choose a particularly sporty suspension response or a distinctly comfortable one at the touch of a button.

And for a perfect driving experience not only on any road, but in any weather too, you can choose the optional 4MATIC all-wheel-drive system. It is available for the C 280 and C 350 petrol-powered Saloon models and for the C 320 CDI diesel versions of the Saloon and the Estate. As well as improving grip on wet roads, for example, 4MATIC offers a noticeably more dynamic driving experience in the dry, too.



Engines with the power to move you

The C-Class diesel models with common-rail technology

Three efficient and powerful CDI engines are available for the new C-Class. The C 320 CDI boasts a six-cylinder common-rail unit with an output of 165 kW (224 hp) which accelerates the car to 100 km/h in 7.7 seconds (Estate: 7.9 s).

The two 4-cylinder models, the C 200 CDI and C 220 CDI, have undergone numerous technical enhancements and now deliver even more power and significantly more torque. Thanks to the improved piston cooling provided by the enlarged oil spray nozzles as well as an optimised oil supply to the plain bearings, the C 200 CDI now develops 100 kW (136 hp) and the C 220 CDI has an output of 125 kW (170 hp). Moreover, metal glow plugs have been replaced in both engines by ceramic ones which are able to attain higher temperatures for improved cold-running properties.

Furthermore, the diesel engines are equipped with a particulate filter¹.

¹ Not available in all countries

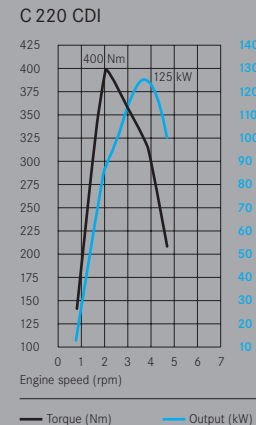

C 220 CDI: Thanks to a number of factors, including a reduced compression ratio and an optimised charge-air cooler, the maximum torque of the C 220 CDI has increased to 400 Nm and its output to 125 kW (170 hp)

It's more than engineering. It's performance art

4-cylinder supercharged petrol engines

You can choose between five different petrol engines for the new C-Class. The range begins with two 4-cylinder supercharged models: the C 180 KOMPRESSOR and the C 200 KOMPRESSOR. Output and torque have been increased by new engine-management software and the modified shape of the pistons. As a result, the C 180 KOMPRESSOR now has an output of 115 kW (156 hp) and a maximum torque of 230 Nm while the C 200 KOMPRESSOR delivers 135 kW (184 hp) and 250 Nm. Acceleration from 0 to 100 km/h takes just 9.5/8.6 seconds (Estate: 9.8/8.8 s) and the respective top speeds are 223/235 km/h (Estate: 218/228 km/h).

C 200 KOMPRESSOR

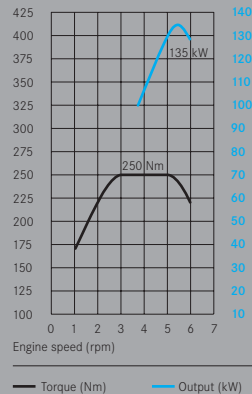

C 200 KOMPRESSOR: With a 15-kW (21-hp) increase in output and an extra 10Nm of torque, the new C 200 KOMPRESSOR now accelerates even more powerfully across the entire engine speed range



If it all went too fast for you out on the road, catch up on the facts and figures here

The V6 petrol engines: the strong, silent types

The three 6-cylinder powerplants in the C 230, C 280 and C 350 offer an inimitable combination of smoothness and power for refined performance. The maximum torque of 245, 300 and 350 Nm is available across an exceptionally broad engine speed range, ensuring that you always have impressive power reserves to call on.

Exemplary fuel use is common to all the V6 engines, thanks to four precisely adjustable camshafts whose timing can be optimised in line with changing requirements. This system ensures that the engines are always provided with exactly the right amount of fuel for the driving situation.

The C 230 has an output of 150 kW (204 hp) while the C 280 delivers 170 kW (231 hp). The C 350, serves up an impressive 200 kW (272 hp). It accelerates from 0 to 100 km/h in just 6.4 seconds (Estate: 6.5 s), placing it on

a par with sports cars – although this is a vehicle which offers considerably more comfort.

The versions equipped with V6 engines, which use fuel particularly sparingly, can be identified externally by the dual-flow exhaust system.

C 350

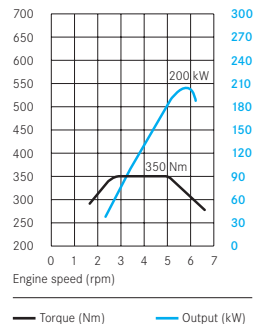

C 350: The new C 350 with a maximum torque of 350 Nm and an output of 200 kW (272 hp)

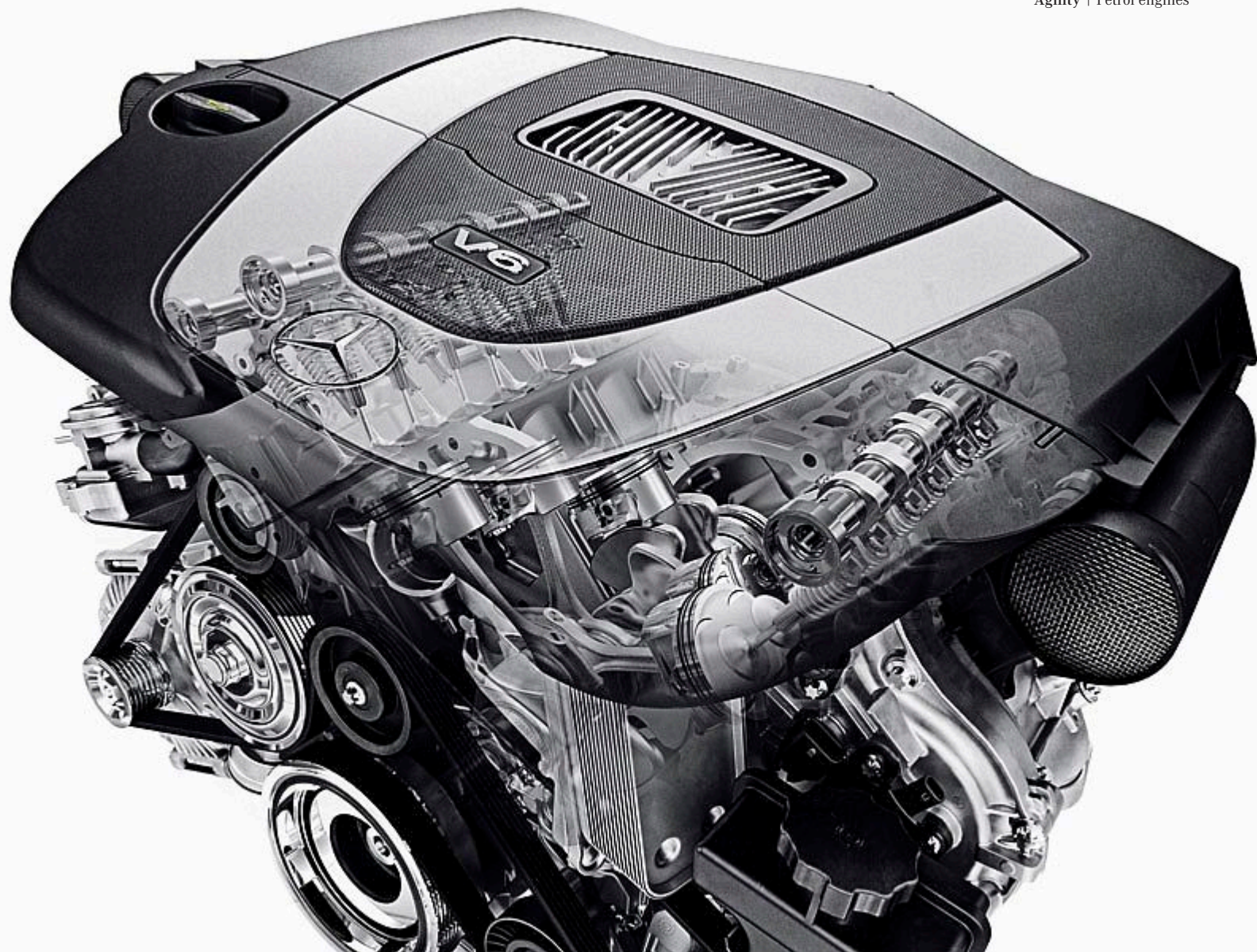

We've stepped up a gear or two so that you can enjoy faster shifting

Transmission technology in the new C-Class

The C-Class is fitted as standard with a 6-speed manual transmission with a particularly short shift throw which makes changing gear a joy. The C 320 CDI features a new, modified transmission ratio, specially tuned to this model's high torque, which peaks at 510 Nm.

If you're looking for even faster gear changes, why not let the C-Class do the work for you? A 5-speed automatic transmission is available as an option for all 4-cylinder models. The highlight of our transmission range, the 7G-TRONIC 7-speed automatic transmission, is fitted as standard in the C 350 as well as the 4MATIC models and is available as an option for all other 6-cylinder models. The seven forward gears permit optimum rev levels at all times and make for almost imperceptible gear changes. 7G-TRONIC can also skip individual gears when down-shifting for quicker bursts of speed.



A nice touch: If your car is fitted with an automatic transmission and you want to change up or down a gear manually, simply nudge the selector lever to the right or left



An even more compelling driving experience at the touch of a button

The dynamic handling package for the new C-Class

The dynamic characteristics of the new C-Class set the standard by which all vehicles in this segment are judged – a standard which is raised even further by the optional dynamic handling package with sports mode. A touch of a button is all it takes to choose a distinctly comfort-oriented driving experience or a compellingly sporty one. With sports mode selected, the system adjusts not only the firmness of the damping, but also sharpens the accelerator response. Assuming, of course, that you are in the mood for it. Otherwise, you can simply choose the comfort mode and enjoy a particularly smooth and comfortable ride.

Whatever the selected mode, the electronically controlled damping system constantly adjusts to the driving situation and the condition of the road. The result is a smoother ride, increased handling safety and, above all, greater agility. The dynamic handling package includes innovative

speed-sensitive sports steering which uses a modified steering response map to deliver a particularly sporty feel. This sensation is complemented by the lower-slung chassis (15 mm lower) which makes fast corners even more enjoyable.



Dynamic handling package: The dynamic handling package allows you to match the C-Class to your mood. A touch of a button is all it takes to give the vehicle a distinctly sporty handling response. Vehicles equipped with 7G-TRONIC benefit from an additional, noticeable reduction in shift times when in sports mode



The C-Class makes the best of bad weather

High traction with 4MATIC all-wheel drive

When contending with loose gravel, snow or challenging inclines, 4MATIC all-wheel drive distributes the engine power to the wheels that need it most. It interacts intelligently with the Electronic Stability Program ESP®, acceleration skid control ASR and the 4MATIC-specific electronic traction system 4ETS to increase both directional stability and traction – particularly where road conditions are difficult.

4MATIC permanent all-wheel drive is available for the C 280, C 350 and C 320 CDI Saloons as well as for the C 320 CDI Estate. All 4MATIC models are equipped as standard with the 7G-TRONIC 7-speed automatic transmission.

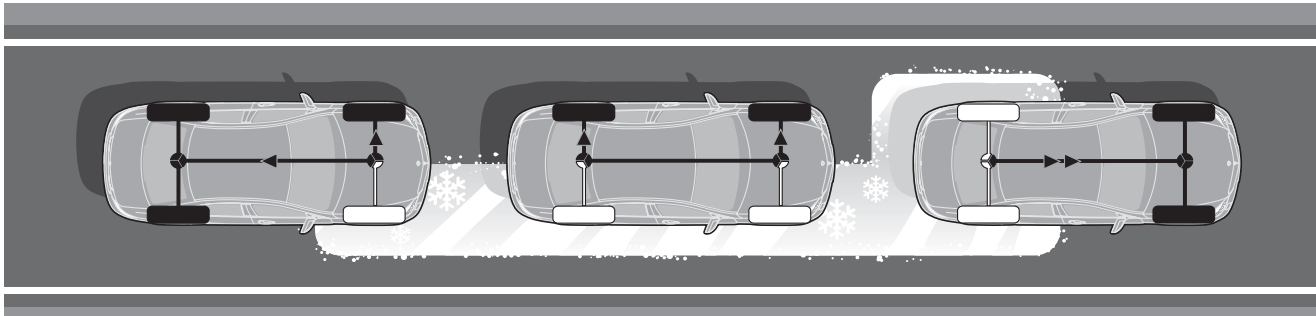

4ETS: In the 4MATIC models the ETS electronic traction system is adapted to the special requirements of all-wheel drive. It automatically diverts the drive torque to the wheels with the best grip





C350



D S ON3811





Why long trips are going to seem much too short from now on

The interior of the new C-Class

With its soft materials, fine trim elements and more space than ever, the interior of the new C-Class is particularly inviting. Shoulder and elbow room has been increased, and rear-seat passengers will also quickly feel at home thanks to their increased legroom. The exceptional ambience of the interior is heightened further by numerous attractive design details with chrome, wood or aluminium trim, depending on the model and your preferences. With a wide range of optional equipment highlights to choose from, including the new panoramic sliding sunroof, which features a particularly large glass area, driving the C-Class is a joy that, quite literally, knows no bounds.



Take a seat: Not just a new look: the upper-leg and lateral support areas of the seat cushions are now firmer, helping to keep you fresh and alert when on the move



You've worked hard enough. Now it's our turn

Stress-relieving comfort in the new C-Class

A driving environment which allows you to concentrate on the task in hand is not just a luxury, it is also a major safety feature. It all starts with the well-designed driver's area. The new dashboard allows you to take in all the necessary information at a glance. The instrument cluster, with its three round displays, is situated in the driver's immediate field of vision and provides information about key operating parameters. Depending on the equipment version, you can use the multifunction steering wheel for easy and convenient control of various features while keeping both hands on the steering wheel. And with the optional KEYLESS-GO function, you can drive off without even having to turn an ignition key.

A comfortable travelling environment comes courtesy of THERMATIC 2-zone automatic climate control which is fitted as standard in the new C-Class. As an option, you

can specify THERMOTRONIC 3-zone luxury automatic climate control which, among other things, allows the temperature of the rear section of the passenger compartment to be set independently as well.



An easy touch: The instruments and systems have intuitive controls. The press of a button is all it takes to adjust audio settings, in-car entertainment selections or, here, the temperature

Soft on the outside, firm on the inside

The secrets of exceptional travel comfort

Equipped on the driver side with a lumbar support for enhanced lower-back comfort, the newly developed front seats are electrically adjustable for cushion height and backrest angle. These settings, in combination with others such as the steering wheel position, head restraint height and exterior mirror position, can be stored by means of the optional memory package. This allows three different configurations to be recalled at the touch of a button.

Also available as an optional extra, the multicontour seat has adaptive air chambers for even greater comfort.

It allows you to adjust the contours of the backrest – in the lumbar region, for example – and the seat cushion length to suit your own requirements and preferences.

If it's the dynamic side of the new C-Class that interests you most, there's the optional AMG sports package which includes seats with more pronounced contours for even greater lateral support. Other optional extras include leather upholstery. Depending on the line, this is available in the form of either man-made leather or genuine leather in a choice of attractive colours.







Typical Mercedes: a navigation system that's a real turn for the better

The new COMAND APS multimedia navigation system

The optional COMAND APS control and display system guides you directly to your destination, helping you to arrive fresh and composed. It combines audio, telephone and navigation functions. With its newly developed interface, COMAND APS is now more intelligent and user-friendly than ever – despite having considerably extended functionality.

The pivoting 7-inch display with new graphic elements and colours is now at the same level as the instrument cluster and is therefore ideally positioned in the driver's field of vision. COMAND APS can be controlled either via an input array in the centre console or via the controller which falls conveniently to hand in front of the armrest. Moreover, all key functions can now also be called up by means of a voice recognition function: the destination input section of the navigation system has whole-word recognition capability for all place names and road names, a stored telephone number can be dialled simply by saying

the name associated with it and you can even set the system up to read out your text messages. Bluetooth functionality is also integrated to allow safe hands-free mobile phone operation and the DVD player is compatible not only with video and audio DVDs, but with CDs and MP3 files too. Up to 1000 MP3 music tracks can be stored on the hard disc of the navigation system.



All at your fingertips: The armrest is designed in such a way that the controller automatically falls to hand. It offers a particularly fast, easy and intuitive way of adjusting the full range of COMAND APS settings



A chauffeur-driven feel

The new C-Class: setting the benchmark for comfortable suspension and low noise levels

The C-Class has always been synonymous with outstanding ride comfort. The aim of our engineers was therefore to raise the standard yet again. As a result, the new C-Class features a selective damping system. The standard-fit AGILITY CONTROL package automatically adjusts the dampers at each wheel to a harder or softer setting according to the current driving situation, ensuring a significantly smoother ride than conventional dampers, especially on poor road surfaces.

Low interior noise levels are a prerequisite for a relaxing driving experience. To eliminate wind noise from the C-Class interior even more effectively, we have optimised the shape of countless bodywork details and further improved the sound insulation.

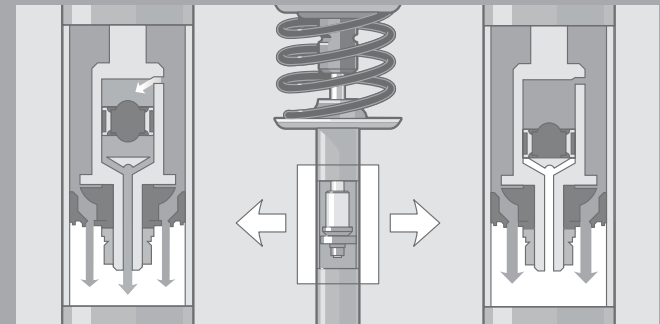

Selective damping system: Softer shock absorber characteristics ensure an extremely smooth ride in normal mode. For dynamic driving the full damping force is made available to stabilise the vehicle



If you need more space, we have the real estate

Simply more possibilities

Every day brings its challenges, be they large or small, personal or professional. It is only natural, therefore, that anyone who wants to be prepared for any situation should set particularly high standards when it comes to choosing an Estate, not least with regard to the variability of the load compartment. So we took special care to address these needs comprehensively during the development of the new C-Class Estate – with the handy stowage nets, the 485 to 1500-litre load capacity (particularly impressive in this segment) and the EASY-PACK load-securing kit. All the details have been fully thought-out and are geared to the same objective: ensuring your comfort.

The new C-Class Estate also impresses with its extremely high payload of up to 605 kg¹ as well as its remarkable towing capacity of up to 1800 kg. What's more, when you make use of the latter, you benefit from the additional safety offered by the trailer stabilisation functionality of the vehicle's ESP[®] system. A range of options, including automatic opening/closing functionality for the tailgate and a new type of self-levelling suspension for optimum load compensation, enhances the everyday practicality of this all-rounder even further.

¹As per DIN





PRO-SAFE™

THE INTEGRAL SAFETY CONCEPT
FROM MERCEDES-BENZ

A theory which can save lives in practice

PRO-SAFE™: the integral safety concept from Mercedes-Benz

Few, if any, fields of activity inspire us to produce such consistently impressive results as researching new safety technologies. As early as the 1950s, we passed an important safety milestone when legendary vehicle safety pioneer Béla Barényi invented the passenger safety cell.

This era also saw revolutionary ideas put forward by many others – such as Rolf Maier. In order to be able to study the crash performance of steering and restraint systems quickly and cost-effectively, Maier and his engineer colleagues designed and built a special sled which was to be driven into a wall at high speed. When they needed to create a crumple zone, the team came up with a simple, yet brilliant solution: gherkin tins from the staff restaurant – a typical example of the creative spirit which characterised this pioneering time.

Much as we like to reflect on the past, though, our focus has always been firmly on the future. The best example is our vision of accident-free driving which is closer today

than ever before thanks to PRO-SAFE™. This integral safety concept from Mercedes-Benz divides automotive safety into four phases.

To ensure a safe journey throughout, the vehicle helps the driver to identify critical situations promptly and handle them safely. In the second phase, where a risk has been detected, numerous preventive measures can be activated to reduce the risk of injury. In the event of an accident, the occupants can benefit from effective, individualised protection provided by the comprehensive range of passive safety systems. Finally, the fourth component comprises the phase after the accident when further measures come into play – to make the task of the rescue services easier, for example.

Additional information about the Mercedes-Benz safety concept is available on the Internet at:
www.mercedes-benz.com/airbag-brochure

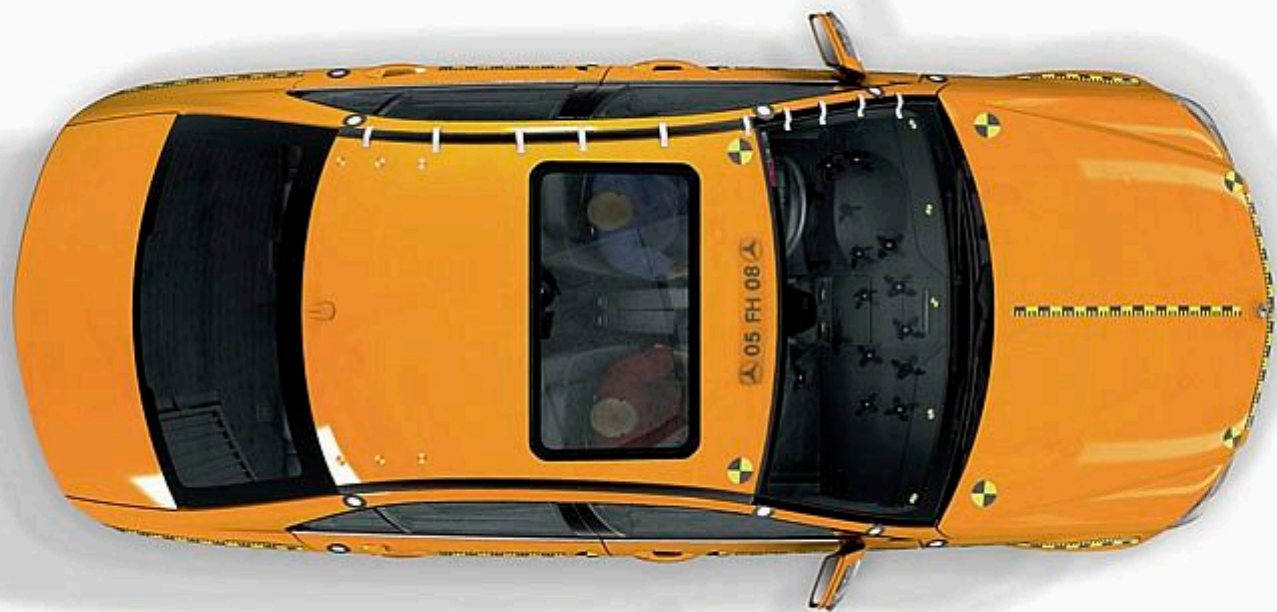

Focusing on helping you to stay focused

Drive safely, and avoid dangers before they have a chance to develop

The majority of accidents start long before the actual collision: with a lapse in concentration, poor visibility or an unexpected hazard. The new C-Class is therefore fitted with safety systems which promote relaxed motoring and help you to bring critical situations under control.

For example, the COMAND control and display system as well as LINGUATRONIC voice control, both of which are available as options, allow you to keep both hands on the steering wheel. When driving, you can also count on over 60 electronic support systems. Some are designed to alert you in the event of a problem – the tyre pressure loss warning system, for example. Others are there to provide active assistance, such as the Electronic Stability Program ESP®, Brake Assist BAS and, for the first time in the C-Class, ESP® trailer stabilisation. The ESP® and BAS sensors can detect hazardous driving situations – such as pronounced

oversteer or understeer, dramatic steering movements, emergency and panic braking – and can assist the driver accordingly.

A new addition to the C-Class is the optional Intelligent Light System, based on the bi-xenon headlamps. It automatically adapts the low-beam lights to the given driving situation, providing broader illumination of the road on extra-urban roads and improving long-range visibility on motorways. The Intelligent Light System also includes enhanced fog lamps, which significantly improve illumination of the driver's side of the road. Other components of the Intelligent Light System include the active light and cornering light functions. With these, the headlamps follow your steering movements, lighting up bends in the road more effectively.

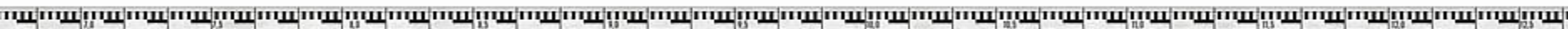

Some hazards arise in next to no time. Some protective systems are even faster

The PRE-SAFE® anticipatory occupant protection system

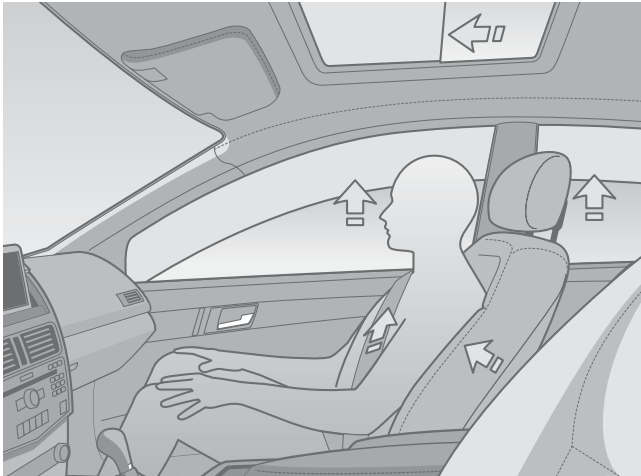

Mercedes-Benz presented PRE-SAFE® in 2002 with one particular objective in mind: the valuable seconds which precede an accident usually elapse unused. The optional PRE-SAFE® system is designed to make effective use of them. The ESP® and BAS sensors identify potentially dangerous situations such as strong oversteer or understeer, critical steering movements, panic braking or emergency braking.

PRE-SAFE®: If there is an immediate danger of an accident occurring, the optional PRE-SAFE® system can tighten the seat belts, close the side windows and the optional tilting/sliding sunroof or panoramic glass roof and move the seats into a more favourable position (in conjunction with electrically adjustable seats and memory package)





There's more. PRE-SAFE® electronically evaluates this information and, when faced with situations which are typically associated with hazards, it triggers precautionary measures to protect the occupants - including automatic tautening of the seat belts, automatic repositioning of the front passenger seat (provided it is electrically adjustable and equipped with the memory function) and automatic closure of the side windows and the optional tilting/sliding sunroof or panoramic glass roof.

In the event of emergency braking, the adaptive brake lights are also activated, their flashing mode providing a more noticeable warning to following traffic than conventional brake lights.

If it comes to the crunch, you can trust Mercedes to cushion the blow

Restraint systems and the passenger safety cell can protect you and others effectively in an accident

Numerous occupant protection systems can significantly reduce the risk of injury in an accident. In the event of a rear-end collision, for example, sensors cause the standard-fit NECK-PRO head restraints for the driver and front passenger to deploy in a matter of milliseconds to reduce the distance between the seat occupant's head and the head restraint.

The C-Class is equipped with belt tensioners on the front and outer rear seats, plus numerous airbags, including two-stage driver and front passenger airbags, sidebags,

and windowbags whose protection zone covers virtually the entire area of the side windows. The sidebags and windowbags are also triggered by pressure sensors: if the door deforms in a side-on collision, the increase in air pressure between the outer door panels and the interior of the door is registered by the pressure sensors, which assist the control unit in deploying the airbags.

Protection also extends to other road users, however, thanks to features such as smooth body surfaces with a generous degree of predefined yield.

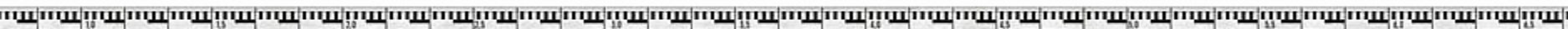

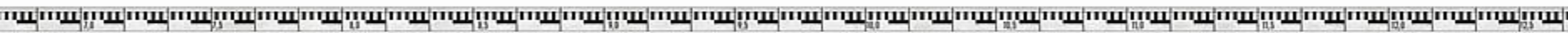

Your Mercedes may have been immobilised, but that doesn't mean it can't still help you

Safety after the event: helping to prevent further damage and speed up the rescue effort

In order to prevent further damage being caused following an accident and to assist with the task of rescuing the occupants, the C-Class is able to take various measures depending on the type and severity of the accident: the engine can be turned off automatically and the fuel supply cut. The hazard warning lights and emergency interior lights can be activated automatically, the side windows partially lowered, if necessary, and the doors automatically unlocked. To complete its holistic safety philosophy, Mercedes-Benz has also published multilingual rescue guidelines (accessible online worldwide at www.mercedes-benz.com/rescue-guidelines) as an additional aid for the emergency services.





C 320



CDI

D S ON 1464



M.F.F.

Helle ylt

GAS

Steng hovedk
for ombordkj
Please close
valve before

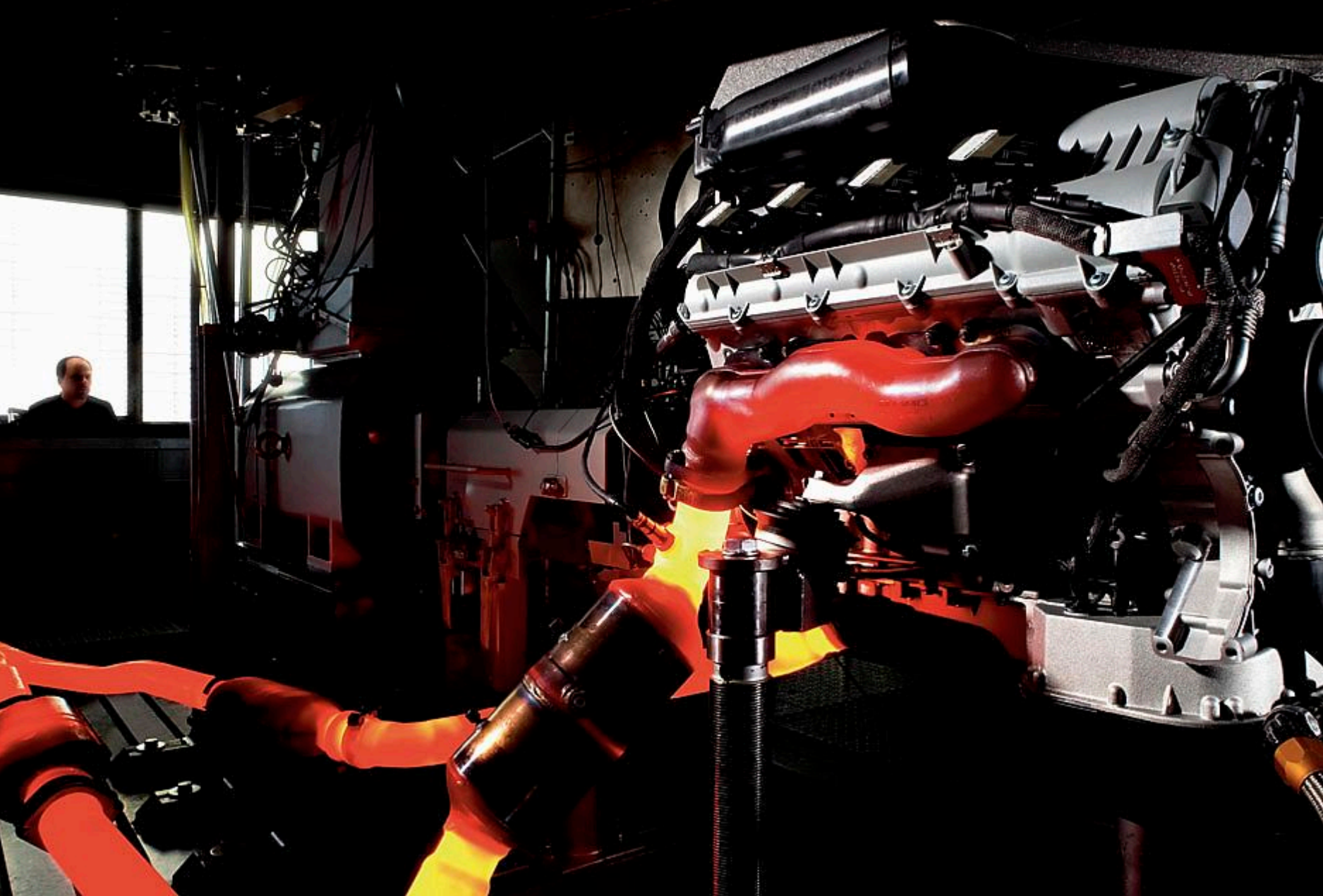

Precision is the hallmark of AMG, passion is its driving force

Mercedes-AMG: the motorsport specialists

“One man, one engine” – this philosophy embodies the sense of passion and commitment which strikes anybody who visits the facility in Affalterbach where the AMG engines are crafted. Because each engine – from the installation of the crankshaft to the filling of the oil – is the responsibility of a single experienced engineer. As a result, this specialist unit is able to guarantee the highest quality and reliability for its products. And just so you know who was responsible for the powerplant of your AMG Mercedes, the engine is fitted with a plate bearing the signature of its creator.

Mercedes-AMG has a long tradition of precision engineering. More than 40 years ago, company founders Hans Werner Aufrecht and Erhard Melcher turned their passionate interest in auto engineering into a business: they brought motorsport to the road. Today, AMG creates not only high-performance engines, but also entire vehicle concepts designed to underline the sporty dimension of a Mercedes in every respect.



The sportiest C-Class of all time

The new C 63 AMG

A 6.3-litre naturally-aspirated V8 engine, 336 kW (457 hp), 600 Nm of torque, 0 to 100 km/h in 4.5 seconds (Estate: 4.6 s), top speed 250 km/h – the specification and performance data of the new C 63 AMG speak for themselves.

But the only way to really appreciate the calibre of this exceptional vehicle is to drive it. The fifth generation of the AMG C-Class offers a perfect blend of extraordinarily impressive performance and expressive design. Outstanding power and agility are guaranteed by the combination of the AMG V8 engine and the perfectly matched AMG sports suspension with a newly developed, wider front axle and AMG speed-sensitive sports steering. The 7-speed AMG SPEEDSHIFT PLUS 7G-TRONIC automatic transmission ensures optimum delivery of engine power to the road, enhances driving dynamics with its ultra-smooth downshifts and makes for an even more enjoyable drive with its throttle-blip function. The new, specially optimised three-stage Electronic Stability Program ESP® and the

AMG high-performance brake system also play key roles in delivering a safe and enjoyable driving experience.

But the really great thing about the C 63 AMG is that it is a genuine Mercedes-Benz in every respect – with all that that implies with regard to long-distance comfort, handling and safety – and offers an ideal combination of high performance and everyday practicality.





It's a C-Class, but not as you know it

It only takes one glance to appreciate the exceptional power of the C 63 AMG. The front view is dominated by the two pronounced powerdomes as well as the special AMG radiator grille with its central star and two chromed louvres. The front foglamps at the outer edges of the front apron emphasise the width of the vehicle, as do the flared front wings. The side air vents in the front apron provide an outlet for the heat from the additional oil-cooler. When equipped with the optional bi-xenon headlamps or the Intelligent Light System, the C 63 AMG features dark-tinted headlamp lenses.

The side view is dominated by the high-sheen 18-inch AMG light-alloy wheels painted in titanium grey, as well as the attractively integrated "6.3 AMG" legend on the wings and the AMG side skirts. At the back the tone is set by characteristic brand design cues: the AMG rear apron with its black diffuser insert and three distinctive diffuser fins as well as the AMG sports exhaust system with two

chromed twin tailpipes and standard-fit LED rear lights. The AMG spoiler lip on the boot lid reduces lift and provides greater directional stability and road adhesion.

Exclusive optional features are available for the C 63 AMG from the AMG *PERFORMANCE STUDIO*. These include the AMG Performance Package, high-sheen 19-inch multi-spoke AMG light-alloy wheels painted in titanium grey and AMG carbon-fibre trim elements.





An interior full of sporty highlights

Inside the new C 63 AMG, exclusive AMG sports seats with integral head restraints and adaptive backrests are fitted as standard. Upholstery is available in ARTICO man-made leather/AMG fabric in black and reef grey. If optional fine nappa leather is specified for the upholstery of these seats, the door centre panels and door armrests are also finished in nappa leather, the available colour combinations being black, reef grey or black/sahara beige. Exceptional sportiness is also the dominant theme throughout the rest of the interior. The cockpit features an AMG instrument cluster with the characteristic tubular design while the three-spoke AMG performance steering wheel has a flattened lower segment and is equipped with authentic motorsport-style shift paddles. AMG door sills, aluminium

trim elements, the black roof lining and the brush stainless-steel sports pedals complete this distinctly sporty interior.







My new C-Class



The C-Class from its three most attractive sides

The CLASSIC, ELEGANCE and AVANTGARDE design and equipment lines



The new C-Class is packed with technology which automatically adjusts to the driver and his or her driving style. And its three design and equipment lines are intended to reflect your personal style too – whether you prefer a classic, elegant or avant-garde look.



The CLASSIC design and equipment line

One look at the exterior of the C-Class CLASSIC is enough to confirm that it has all the typical Mercedes-Benz characteristics: the chromed radiator grille is embellished with the laurel wreath badge with the hallmark star standing above it on the bonnet. Fine chrome defines the top of the window areas and three black louvres add emphasis to the front air intakes. The fog lamps also have black surrounds.



Chromed and black trim elements at the front of the C-Class CLASSIC

The colour concept continues all the way to the rear with the wide matt black handle.

The C-Class CLASSIC also comes fitted with attractive 7-spoke light-alloy wheels as standard (available as an option for the C 200 CDI and C 180 KOMPRESSOR).



At the rear, the matt black handle identifies the CLASSIC line



The CLASSIC design and equipment line for the C-Class Estate

Featuring a chromed radiator grille embellished with the laurel wreath badge and the star standing on the bonnet, the C-Class CLASSIC Estate has all the inimitable exterior characteristics of a genuine Mercedes-Benz. This design and equipment line is made all the more attractive by the three black air-intake louvres and the front foglamps which also have black surrounds. The black roof rails and the matt-black tailgate handle also complement the harmonious colour scheme.

From the C 220 CDI or C 200 KOMPRESSOR upwards, all models are equipped with attractive light-alloy wheels as standard (the C 200 CDI and C 180 KOMPRESSOR are equipped as standard with steel wheels and wheel trims). The exterior design concept is taken up by the interior which has a classic black or reef grey finish. High-quality chrome details complement the fine trim elements with their piano-lacquer-effect finish (burr walnut is available

as an alternative) to further enhance the stylish ambience. The seats are upholstered in Brighton fabric in black, reef grey, black/beige or black/red while ARTICO man-made leather upholstery is available as an optional extra.



High-quality materials are used in the load compartment, too



The CLASSIC design and equipment line – interior

The interior, too, retains its classic feel, finished either in black or reef grey. Fine piano-lacquer-effect trim elements are supplemented with high-quality chrome details. The trim elements are also available in burr walnut as an option.



Numerous chrome details harmonise with the piano-lacquer-effect trim elements

Specially designed with horizontal seamlines, the seats are upholstered in black, reef grey, black/beige or black/red Brighton fabric, but can be finished in ARTICO man-made leather as an option.



Comfortable and elegant: the new seats with attractive fabric panels



The ELEGANCE design and equipment line

The first time you set eyes on your C-Class ELEGANCE is a very special moment. From the star standing on the bonnet, your gaze travels to the fog lamps with their elegant chrome surrounds. More chrome elements can be seen on the bumpers, wings and doors. The polished aluminium



Numerous chrome trim elements lend the front its elegant character

shoulderline trim strip adds a particularly stylish highlight to the sides of the new C-Class. The rear of the C-Class ELEGANCE is distinctive with its chromed handle. 12-spoke light-alloy wheels provide a dazzling finishing touch.



Gleaming chrome is also used for the boot lid handle



The ELEGANCE design and equipment line for the C-Class Estate

Truly elegant design is always eye-catching – as in the case of the front section of the C-Class ELEGANCE, for example. The new, sculpted headlamps and the foglamps with their attractive chrome surrounds set the tone for the thoroughly elegant statement made by the chrome details on the bumpers, wings and doors and reinforced by the polished aluminium shoulderline trim strip and roof rails.

The tailgate of the C-Class ELEGANCE is equally distinctive with its chromed handle, while 12-spoke light-alloy wheels provide a dazzling finishing touch. Subtle colours characterise the interior. The Edinburgh fabric is available in black, reef grey or savanna beige. ARTICO man-made leather or genuine leather upholstery can be specified as optional extras. Burr walnut can be specified as an option instead of the standard fine-grain eucalyptus wood trim elements. Both harmonise beautifully with the stylish

leather steering wheel which is standard in this design and equipment line.



The elegant design extends to the load compartment, too



The ELEGANCE design and equipment line – interior

Inside, the tone is set by a discreet combination of colours. The Edinburgh fabric is available in black, savanna beige/cashmere beige or reef grey. As an option, the comfortable seats can also be upholstered in ARTICO man-made leather or genuine leather. A leather steering wheel is fitted as



The natural beauty of the eucalyptus wood trim elements

standard. Upholstered in fabric or leather, the seats have decorative vertical stitching and the trim elements are in fine-grain eucalyptus. The interior can also be trimmed in burr walnut as an option.



The seats can be upholstered in leather – for example in reef grey – as an option



The AVANTGARDE design and equipment line

The AVANTGARDE design and equipment line turns the new C-Class into a particularly distinctive Mercedes. The agility of this model is conveyed instantly by the look of the front featuring a wide radiator grille with three bright silver louvres, distinctive chrome strips and the dominant star set in the centre. Chrome highlights – on the bumpers,



Striking and powerful: the new face of the AVANTGARDE line

wings and doors, for example – emphasise the elegant profile of the C-Class and are complemented by the polished aluminium shoulderline trim strip and the chromed handle at the rear. Dark-tinted tail lights are another distinctive feature of the rear of the C-Class AVANTGARDE.



Embellishments at the rear include a chrome handle



The AVANTGARDE design and equipment line for the C-Class Estate

Avant-gardists always stand out – and the C-Class AVANTGARDE is no exception, its front instantly conveying the vehicle's agility through its wide radiator grille with three bright silver louvres, and the dominant star set in the centre. Chrome highlights on the bumpers, wings and doors emphasise the sleek lines of the C-Class. Particularly eye-catching touches include the polished aluminium shoulderline trim strip and roof rails as well as the chromed handle at the rear and the chrome band which runs round the whole vehicle.

Sportiness is the dominant theme inside the vehicle: the dashboard and floor are black while the door centre panels and door armrests are black or reef grey. Matt aluminium trim elements underline the sporty look. Wood trim elements in black bird's-eye maple are available as an option. The sporty theme continues with the standard Liverpool fabric/ARTICO man-made leather upholstery in black or reef grey.

For a more contrasting interior, two-tone leather upholstery in black/sahara beige and black/cognac brown is available as an optional extra.



The sporty look and feel continues all the way into the load compartment



The AVANTGARDE design and equipment line – interior

Contrasting colours and materials lend the interior its sporty character. The floor, dashboard and, optionally, the roof lining are black while the door centre panels and door armrests are black or reef grey. Finely textured aluminium trim elements emphasise the clean, sporty look. Wood trim elements in black bird's-eye maple are available as an option. The seats are distinguished by horizontal

stitching and are upholstered as standard in a Liverpool fabric/ARTICO man-made leather combination in black or reef grey. The door centre panels add further striking touches if optional two-tone leather upholstery – in a black/sahara beige or black/cognac brown combination – is specified.



Aluminium trim for a refined, sporty look



The horizontal stitching adds to the dynamic ambience



	CLASSIC	ELEGANCE	AVANTGARDE
Exterior			
B-pillar trim	Matt black	High-gloss black	High-gloss black
Boot lid/tailgate handle	Matt black	Chromed	Chromed
Bumpers and side panels	Body colour	Body colour with chrome trim strips	Body colour with chrome trim strips
Fog lamp surrounds	Black surround	Chrome surround	Chrome surround with two chrome bars
Line badge	Wings without line lettering	New-look ELEGANCE line lettering on the wings	New-look AVANTGARDE line lettering on the wings
Radiator grille	3 louvres, chromed, star on bonnet	3 louvres, chromed, star on bonnet	3 louvres, brilliant silver, central star on radiator grille
Shoulderline trim strip	Matt black	Polished aluminium	Polished aluminium
Tail lights (in conjunction with projection-beam headlamps)	Pale meander	Pale meander	Dark meander
Wheels	16-inch 7-spoke light-alloy wheels, 16-inch steel wheels with wheel trim for C 200 CDI and C 180 KOMPRESSOR	17-inch 12-spoke light-alloy wheels for C 320 CDI and C 350, 16-inch 12-spoke light-alloy wheels for all other models	17-inch 5-twin-spoke light-alloy wheels
Interior			
Gearshift console	Polyurethane shift lever gaiter, black plastic surround	Leather shift lever gaiter, chrome surround	Leather shift lever gaiter, chrome surround
Instrument cluster	Backplate in black	Backplate in black	Backplate in titanium silver
Seat design	Large panels with horizontal stitching	Thinly spaced vertical stitching	Sporty horizontal stitching
Steering wheel	Polyurethane-foam multifunction steering wheel	Luxury multifunction steering wheel in leather with 4.5-inch display in the instrument cluster	Luxury multifunction steering wheel in leather with 4.5-inch display in the instrument cluster
Trim elements	Piano-lacquer-effect finish	Eucalyptus wood	Aluminium
Upholstery	Brighton fabric	Edinburgh fabric	Liverpool fabric / ARTICO man-made leather



The AMG sports package¹

If you would like to give your C-Class an even sportier character, the optional AMG sports package offers an attractive combination of features: a dynamic AMG front apron, side skirts and a distinctive AMG rear apron as well as 17-inch 6-twin-spoke AMG light-alloy wheels with mixed-size tyres (225/45 at the front and 245/40 at the rear). You can also opt for 18-inch 5-twin-spoke AMG light



Powerful: AMG rear apron and 17-inch AMG light-alloy wheels

¹Shown here in combination with the AVANTGARDE line

alloy wheels. The sports suspension, which is lowered by 15 mm, actively helps to enhance driving pleasure – as does the speed-sensitive sports steering. And the perforated front brake discs and brake callipers with "Mercedes-Benz" lettering have a breathtakingly sporty look and deliver reassuring deceleration.



Powerful look, powerful effect: the perforated brake discs



Featuring large air intakes and round fog lights with chrome surrounds, the AMG front apron lends the new C-Class an athletic look. The powerful AMG rear apron, meanwhile,

along with the side skirts and the high-shine 17" 6-twin-spoke AMG light-alloy wheels, gives the dynamic AMG sports package an even keener edge.



Powerful: the AMG front apron



The AMG sports package – interior

The AMG sports package creates a special atmosphere inside the car too: the sports seats provide secure support and, like the rear seats, are upholstered in a Liverpool fabric/ARTICO man-made leather combination. Leather upholstery is available as an option.

Also included in the AMG sports package is a sporty 3-spoke leather steering wheel featuring shift paddles



Behind the 3-spoke leather steering wheel are shift paddles for manual gear changes (in conjunction with automatic transmission)

for gear selection (when fitted in conjunction with an automatic transmission). Brushed stainless-steel sports pedals, black floor mats with AMG lettering, a black roof lining and an aluminium-look shift/selector lever are further highlights of the sporty interior.



AMG through and through: the sports pedals in brushed stainless steel





How much C-Class are you looking for?

The standard equipment and optional extras leave nothing to be desired

Make a wish. The range of optional extras is packed with ideas. Enjoy a view of the stars through the panoramic glass roof. Experience an all-new driving sensation with the dynamic handling package with sports mode. Relax on multicontour seats, or discover just how bright lights can be these days with the Intelligent Light System.

But don't be too disappointed if you find that many of the other highlights you would expect to find among the optional extras aren't there: because they're already fitted as standard.



Standard equipment (selection)

3-point seat belts and head restraints for all seats

6-speed manual transmission¹

Adaptive brake lights

ADAPTIVE BRAKE with ABS, ASR, brake drying function and hill start assist

AGILITY CONTROL suspension with selective damping system

Airbags (front), sidebags (front) and windowbags

ASSYST service interval indicator

Belt tensioners with belt force limiters, front and outer rear seats

Brake Assist BAS

Central locking (remote control with selective and global opening)

Clear-lens fog lamps

Clear-lens headlamps with projection-beam technology

Electronic Stability Program ESP®

Front armrest with stowage facility²

Front seats with electrically adjustable height and backrest angle

Headlamp Assist

Heated exterior mirrors, electrically adjustable, with aspherically curved glass and clear-lens indicators

Heated rear window with time relay

Kneebag for driver (Europe only)

Multifunction steering wheel with trip computer

Outside temperature display

Power windows (4), with one-touch control

Remote boot-lid release, can be operated via key²

Seat occupancy sensor for front passenger seat

THERMATIC 2-zone automatic climate control

¹ 7G-TRONIC 7-speed automatic transmission fitted as standard in C 350, C 63 AMG and 4MATIC models

² Available for C-Class Saloon



Control panel for THERMATIC 2-zone automatic climate control



Designer key

Ever thought of investing in precious metals?

The light-alloy wheels for the new C-Class

The CLASSIC design and equipment line features 16-inch 7-spoke light-alloy wheels (C 200 CDI and C 180 KOMPRESSIONER fitted with steel wheels and wheel trims). The ELEGANCE line features 16 or 17-inch light-alloy wheels as standard, depending on the model. Both have a 12-spoke design. The AVANTGARDE line is supplied with particularly sporty 17-inch 5-twin-spoke wheels. As an option, all models can be equipped with 16-inch 7-spoke light-alloy wheels, 17-inch multi-spoke light-alloy wheels, 17-inch 5-spoke light-alloy wheels or 17-inch 7-twin-spoke light-alloy wheels.



16-inch 12-spoke light-alloy wheel (ELEGANCE)



16-inch 7-spoke light-alloy wheel (CLASSIC)



16-inch 7-spoke light-alloy wheel



17-inch multi-spoke light-alloy wheel



17-inch 5-twin-spoke light-alloy wheel (AVANTGARDE)



17-inch 5-spoke light-alloy wheel



17-inch 7-twin-spoke light-alloy wheel

Rounding off the sporty look

AMG light-alloy wheels

Highly exclusive and sensationally sporty – high-shine 17-inch 6-twin-spoke AMG light-alloy wheels shod with 225/45 tyres at the front and 245/40 tyres at the rear are available in conjunction with the AMG sports package.



17-inch 6-twin-spoke AMG light-alloy wheel (AMG sports package)

High-shine 18-inch 5-twin-spoke AMG light-alloy wheels with size 225/40 tyres at the front and size 255/35 tyres at the rear are available as an optional extra for all models and in conjunction with the AMG sports package.



18-inch 5-twin-spoke AMG light-alloy wheel

If designer footwear is your thing, you've come to the right place

incenio designer wheels

The range of Mercedes-Benz accessories features exclusive incenio light-alloy wheels for the new C-Class: 16-inch

7-spoke "Pristix" designer wheels and 18-inch 5-twin-spoke "Pulaha" designer wheels.



16-inch "Pristix" 7-spoke incenio designer wheel



18-inch "Pulaha" 5-twin-spoke incenio designer wheel

Even traffic bulletins can be a joy to listen to

The radios, navigation systems and surround sound system

The new C-Class provides plenty of listening enjoyment when you're on the move. You can choose between three high-end audio systems, all of which are available as an option.

The Audio 20 radio features a 4.9-inch colour display, a CD player which can also play MP3 files, and Bluetooth functionality. It can also be combined with a 6-CD changer as an option. The Audio 50 APS radio also includes a DVD drive and a DVD navigation system with dynamic route guidance.

The highlight of the on-board entertainment range for the C-Class is the new COMAND APS. You can find out more about it on page 37.

All audio systems (except the Audio 20 without CD changer) can be combined with the Harman Kardon® Logic 7® surround sound system as an option. A DSP amplifier with Logic 7® technology and a total output of 450W as well as 12 high-performance loudspeakers ensure incomparable sound quality – and deliver a breathtaking surround sound experience whether you are listening to stereo or Dolby Digital 5.1 recordings (Audio 20 radio offers stereo reproduction only).



Audio 20 radio with CD drive



Audio 50 APS radio with DVD navigation system

Optional extras (selection)	C 200 CDI	C 220 CDI	C 320 CDI	C 320 CDI 4MATIC	C 180 KOMPR.	C 200 KOMPR.	C 230	C 280	C 280 4MATIC	C 350	C 350 4MATIC	C 63 AMG
5-speed automatic transmission	●	●	-	-	●	●	-	-	-	-	-	-
7G-TRONIC 7-speed automatic transmission	-	-	●	□	-	-	●	●	□	□	□	□
AMG sports package	●	●	●	●	●	●	●	●	●	●	●	-
Anti-theft alarm system with tow-away protection and interior monitoring	●	●	●	●	●	●	●	●	●	●	●	●
Bi-xenon headlamps	●	●	●	●	●	●	●	●	●	●	●	●
COMAND APS control and display system with DVD drive	●	●	●	●	●	●	●	●	●	●	●	●
Cruise control	●	●	●	□	●	●	●	●	□	□	□	□
Dynamic handling package	●	●	●	-	●	●	●	●	-	●	-	-
Folding trailer coupling incl. ESP® trailer stabilisation	●	●	●	●	●	●	●	●	●	●	●	-

● Optional extra □ Standard - Not available



The PARKTRONIC parking aid with visual proximity warning



Rear windscreen roller blind, electric (Saloon only)

Optional extras (selection)	C 200 CDI	C 220 CDI	C 320 CDI	C 320 CDI 4MATIC	C 180 KOMPR.	C 200 KOMPR.	C 230	C 280	C 280 4MATIC	C 350	C 350 4MATIC	C 63 AMG
Harman Kardon® Logic 7® surround sound system, Dolby Digital 5.1 and stereo, 12 loudspeakers, 450 W	●	●	●	●	●	●	●	●	●	●	●	●
Heated front seats	●	●	●	●	●	●	●	●	●	●	●	●
Heated windscreen washer system	●	●	●	●	●	●	●	●	●	●	●	●
Intelligent Light System with bi-xenon headlamps	●	●	●	●	●	●	●	●	●	●	●	●
Interior and driver's-side exterior mirror automatically dimming, exterior mirrors electrically folding	●	●	●	●	●	●	●	●	●	●	●	●
KEYLESS-GO	●	●	●	●	●	●	●	●	●	●	●	●
Memory function for driver's seat, steering column and exterior mirrors	●	●	●	●	●	●	●	●	●	●	●	●
Mounted fire extinguisher	●	●	●	●	●	●	●	●	●	●	●	●
Multicontour front seats	●	●	●	●	●	●	●	●	●	●	●	-

● Optional extra □ Standard - Not available



Intelligent Light System with bi-xenon headlamps



KEYLESS-GO – open the doors and start the engine without even taking the key out of your pocket

Optional extras (selection)	C 200 CDI	C 220 CDI	C 320 CDI	C 320 CDI 4MATIC	C 180 KOMPR.	C 200 KOMPR.	C 230	C 280	C 280 4MATIC	C 350	C 350 4MATIC	C 63 AMG
Panoramic sliding sunroof with electric roller blinds	●	●	●	●	●	●	●	●	●	●	●	–
PARKTRONIC	●	●	●	●	●	●	●	●	●	●	●	●
PRE-SAFE® system	●	●	●	●	●	●	●	●	●	●	●	●
Rear windscreen roller blind, electric	●	●	●	●	●	●	●	●	●	●	●	●
Sidebags in rear	●	●	●	●	●	●	●	●	●	●	●	●
Speed-sensitive power steering	●	●	●	●	●	●	●	●	●	●	●	–
THERMOTRONIC 3-zone luxury automatic climate control	●	●	●	●	●	●	●	●	●	●	●	●
Through-loading facility, folding rear seats ¹	●	●	●	●	●	●	●	●	●	●	●	□
Tilting/sliding glass sunroof	●	●	●	●	●	●	●	●	●	●	●	● ²

● Optional extra

□ Standard

– Not available

¹ Standard for C-Class Estate² Standard for C 63 AMG Estate

Rear control panel for THERMOTRONIC 3-zone luxury automatic climate control



Rear armrest with cup holders

Standard equipment (selection)

 3-point seat belts and head restraints for all seats

 6-speed manual transmission¹

 Adaptive brake lights

 ADAPTIVE BRAKE with ABS, ASR, brake drying function and hill start assist

 AGILITY CONTROL steering

 AGILITY CONTROL suspension with selective damping system

 Airbags (front), sidebags (front) and windowbags

 Anchoring rings with chrome finish

 ASSYST service interval indicator

 Belt tensioners with belt force limiters, front and outer rear seats

 Brake Assist BAS

 Clear-lens fog lamps

 Clear-lens headlamps with projection-beam technology

 Electronic Stability Program ESP[®]

 Front and rear armrests with stowage facility

 Front seats with electrically adjustable height and backrest angle

 Headlamp Assist

 Kneebag for driver (Europe only)

 Multifunction steering wheel with trip computer

 Outside temperature display

 Power windows (4), with one-touch control

 Side luggage nets

 THERMATIC 2-zone automatic climate control

¹7G-TRONIC 7-speed automatic transmission fitted as standard in C 320 CDI 4MATIC, C 350 and C 63 AMG



Integrated child seat (optional extra)



Sunblinds on rear doors (optional extra)

Optional extras (selection)	C 200 CDI	C 220 CDI	C 320 CDI	C 320 CDI 4MATIC	C 180 KOMPR.	C 200 KOMPR.	C 230	C 280	C 350	C 63 AMG
5-speed automatic transmission	●	●	-	-	●	●	-	-	-	-
7G-TRONIC 7-speed automatic transmission	-	-	●	□	-	-	●	●	□	□
AMG sports package	●	●	●	●	●	●	●	●	●	-
COMAND APS control and display system with DVD drive	●	●	●	●	●	●	●	●	●	●
Dynamic handling package	●	●	●	-	●	●	●	●	●	-
EASY-PACK load-securing kit	●	●	●	●	●	●	●	●	●	●
EASY-PACK tailgate	●	●	●	●	●	●	●	●	●	●
Folding trailer coupling incl. ESP® trailer stabilisation	●	●	●	●	●	●	●	●	●	-
Panoramic sliding sunroof with electric roller blinds	●	●	●	●	●	●	●	●	●	-
PRE-SAFE® system	●	●	●	●	●	●	●	●	●	●
Roller sunblinds in the rear doors	●	●	●	●	●	●	●	●	●	●
Self-levelling suspension	●	●	●	●	●	●	●	●	●	-
THERMOTRONIC 3-zone luxury automatic climate control	●	●	●	●	●	●	●	●	●	●

● Optional extra □ Standard - Not available



Panoramic sliding sunroof (optional extra)



EASY-PACK tailgate (optional extra)



As personal as your own handwriting

Individualise your vehicle in line with your own tastes with the designo range

How can you personalise a Mercedes C-Class so that it truly becomes **your** Mercedes? The answer is designo, a range of carefully selected materials which allows you to turn your vehicle into a unique masterpiece. With superb leather appointments, a perfectly colour-coordinated fabric roof liner and matching velour floor mats. As well as having instant appeal, the remarkable quality which characterises the look and feel of even the smallest details of the designo range of appointments is a source of lasting pleasure.

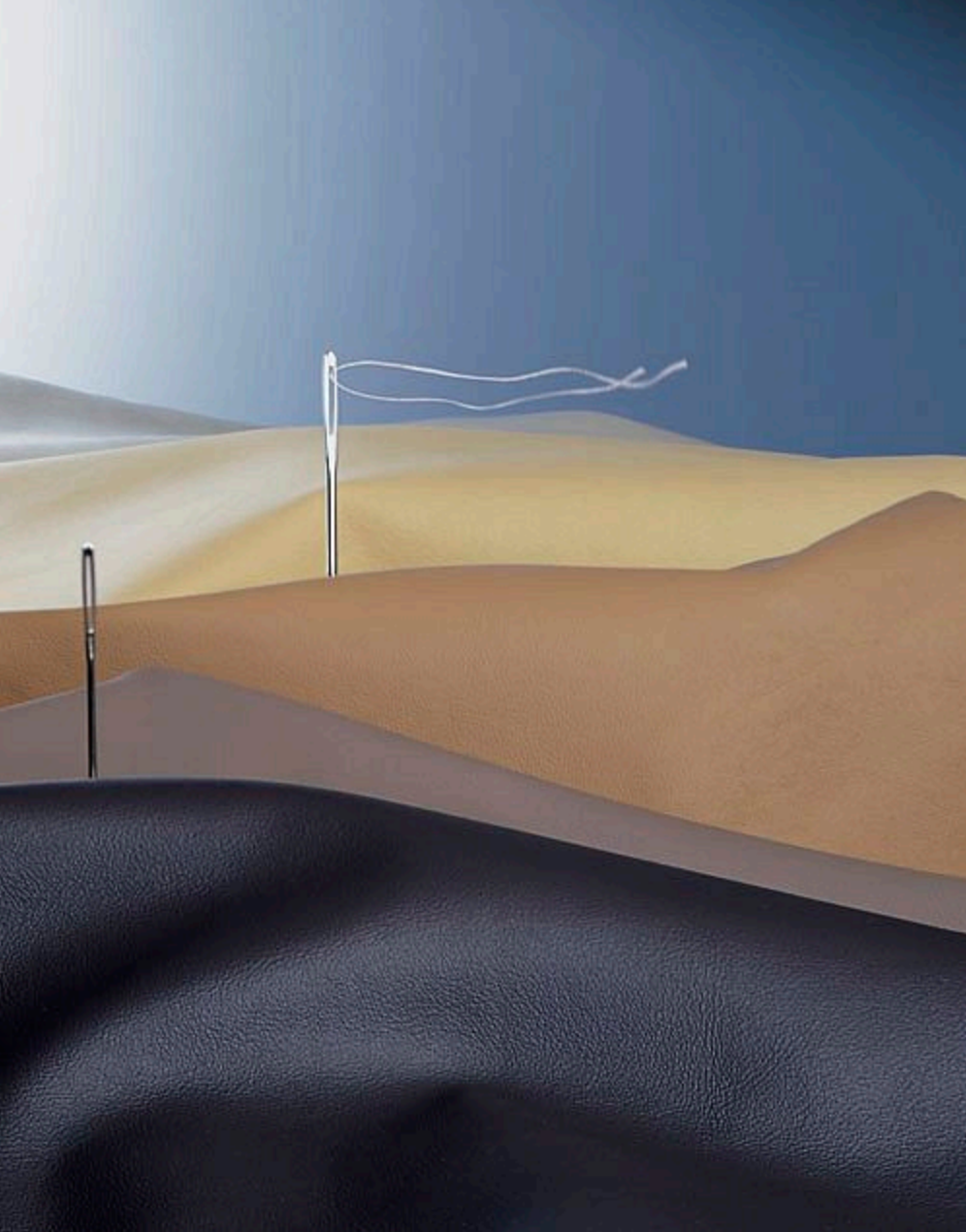

As unique as you are

The designo leather appointments

designo is synonymous with outstanding craftsmanship. Like that of the experienced upholsterers, for example, who painstakingly turn hand-picked hides into beautiful leather appointments. Two of these sets of exclusive designo leather appointments are available for the C-Class Saloon and Estate.

You can choose between the leather colours designo porcelain and designo sand. The designo seating has a characteristic two-tone design with the seat centre



Two-tone: designo leather appointments for the Mercedes C-Class

panels in the chosen designo colour and the side bolsters in black. In addition, high-quality designo metal badges are set into the backrests of the front seats. The interior appointments are completed by the black fabric roof lining and velour floor mats with a designo leather surround in black.

The designo leather appointments are available only in conjunction with the ELEGANCE and AVANTGARDE lines and cannot be specified for the C 63 AMG.



The hallmark of quality and meticulous workmanship: the designo badge





Those special extras

Genuine Mercedes-Benz accessories for the new C-Class Saloon

From attractive to practical – there's a whole selection of extras to choose from in the Mercedes-Benz accessories range.

Take the genuine styling products, for example. The line-up for the new C-Class includes front apron spoiler lips, a rear apron, rear/roof spoilers and incenio designer wheels.



Luxury at your fingertips: the wood/leather steering wheel

The range of accessories has plenty of other extras in store, too, including carrier systems, wood/leather steering wheels, and cup holders. For details of the full range, please see our special C-Class accessories brochure, or contact your Mercedes-Benz dealer who will be happy to help you.



One less reason to break your journey: the cup holder for the centre console



Perfect, right down to the smallest detail

Practical and versatile: genuine accessories for the C-Class Estate

Practicality and attractiveness are defining characteristics of the C-Class Estate. So it's good to know that there is a range of genuine accessories which allow you to enhance it to meet your specific requirements without compromising these key attributes. Suppose you like skiing, for example. A Mercedes-Benz roof box might be just what you need. As well as offering good aerodynamics and very attractive styling, it's also extremely practical and versatile. If cycling's your thing,

by contrast, how about the New Alustyle bicycle rack? Whatever your bent, you'll find loading your C-Class is particularly easy and convenient with our load compartment products. They also ensure the high standards of travelling safety which are synonymous with Mercedes-Benz. The shallow load compartment tub, for example, not only allows items to be carried hygienically but also fits the load compartment perfectly, has a non-slip surface and is food-safe.

The concertina-type folding bag comprises two bags made from tough, washable nylon fabric. Each bag has two large compartments and two handles which make it easy to remove and carry.

For details of other useful items, please see the C-Class accessories brochure which is available separately or contact your Mercedes-Benz dealer.



Alustyle basic carrier bars with New Alustyle bicycle rack



Concertina-type folding bag



Load compartment tub



Irresistibly attractive And extremely resistant

The extra-scratch-resistant clearcoat of the new C-Class

Stars are meant to shine, and if ours seem to shine brighter, it's because we have followed the Mercedes tradition of pioneering new technologies and have developed one of the best clearcoats available in the automobile market. Thanks to this innovative Mercedes-Benz paint system, our vehicles now make an even more impressive visual statement which is also reflected in their even higher value retention. This clearcoat developed by Mercedes-Benz is more resistant than conventional clearcoats by virtue of its particularly dense molecular structure. It also produces a more lasting

and noticeably more intense sheen. Whether you choose a metallic or non-metallic paint finish, this more scratch-resistant clearcoat is less sensitive to weathering and environmental influences, rain and snow, sunlight and temperature fluctuations. It is also more resistant to chemical attack and physical wear and tear, such as that caused by automatic car washes. You can rest assured that your new Mercedes will continue to shine elegantly throughout its long life.

The C-Class paintwork puts the finishing touch to the carefully crafted Mercedes-Benz corrosion protection system, which includes zinc phosphating and electrophoretic dip priming stages for long-lasting protection. Furthermore, Mercedes-Benz makes extensive use of eco-friendly water-based paints.

Non-metallic paints



040 black



590 fire opal

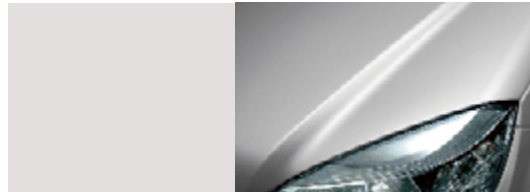

650 calcite white

Metallic paints



197 obsidian black



300 periclase green



359 tanzanite blue

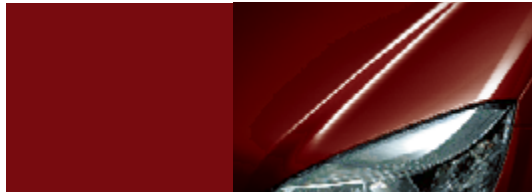

544 carneol red



775 iridium silver

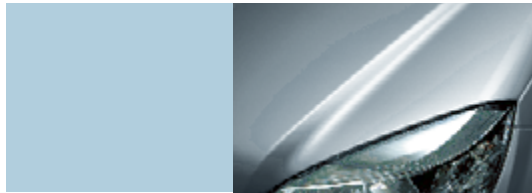

723 cubanite silver

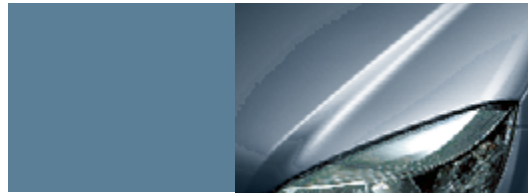

792 palladium silver

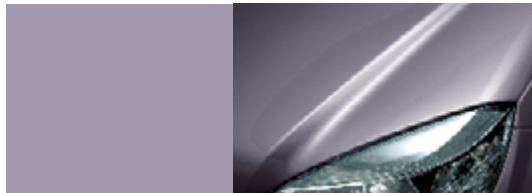

755 tenorite grey



798 sanidine beige

The seats of a Mercedes-Benz offer an extremely high degree of comfort thanks to the special way in which the seat cushions are sprung and the use of separate foam elements for the centre panel of the seat cushion and the sides. The combination of the seat cushion spring set-up, which is precisely tuned to the vehicle, and the selection of the appropriate degree of cushion density results in exceptional springing and damping characteristics. You can create an ideal seating environment which reflects your own preferences by choosing from our range of fabric and/or leather upholstery. New fabric patterns have been developed to complement and harmonise with the different design and equipment lines of the C-Class.

CLASSIC

Brighton fabric



001 black



008 reef grey



055 black/beige



057 black/red

ELEGANCE

Edinburgh fabric



401 black



404 savanna beige/cashmere beige

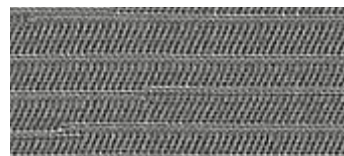

408 reef grey

AVANTGARDE and AMG sports package

Liverpool fabric / ARTICO
man-made leather

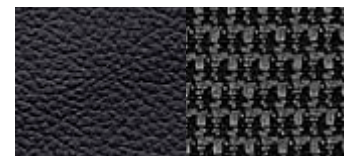

701 black

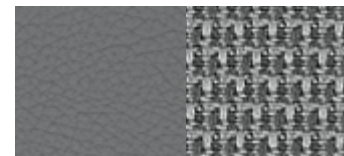

708 reef grey

CLASSIC and ELEGANCE

ARTICO man-made leather

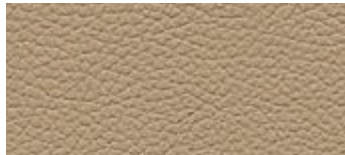
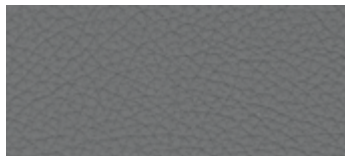

101 black

104 savanna beige/cashmere beige
(for ELEGANCE only)

108 reef grey

ELEGANCE, AVANTGARDE and AMG sports package¹

Leather

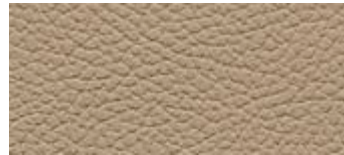

201 black

204 savanna beige/cashmere beige
(for ELEGANCE only)

208 reef grey

AVANTGARDE

Leather



205 black/sahara beige

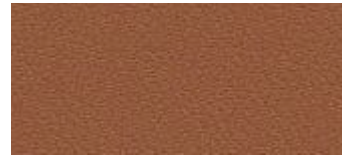

207 black/cognac brown

designoLeather²

X77 sand



X87 porcelain

¹Leather upholstery is only available in conjunction with ELEGANCE and AVANTGARDE in black and reef grey²Only in conjunction with the ELEGANCE or AVANTGARDE design and equipment lines. designo leather appointments are not available for the C 63 AMG

Many hours of care and attention are lavished on every Mercedes-Benz. The wood trim elements are just one example of the craftsmanship involved: it takes around three weeks to turn this natural product into a perfectly finished Mercedes component.

Special computer-controlled planing machines slice the thinnest of veneers from the wood. The ones whose colour and grain characteristics match best are then used to create a complete veneer. This process involves placing the individual layers on thin substrate elements with intermediate layers of aluminium and glue sheets to ensure strength and durability. Up to 100 of these layers are applied by hand to create a trim strip. Take a close look at your new C-Class and you will see how much care has gone into every detail.

CLASSIC

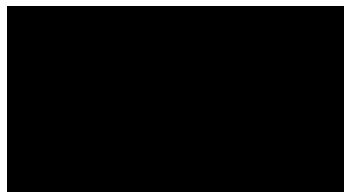

Piano-lacquer-effet finish



Burr walnut

ELEGANCE

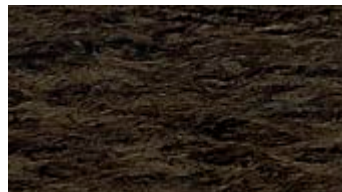

Eucalyptus



Burr walnut

AVANTGARDE



Aluminium



Black bird's-eye maple

	NON-METALLIC PAINTS			METALLIC PAINTS									
	black	fire opal	calcite white	obsidian black	periclase green	tanzanite blue	carneol red	cubanite silver	tenorite grey	iridium silver	palladium silver	sanidine beige	
Brighton fabric (CLASSIC)													
black	●	●	●	●	●	●	●	●	●	●	●	●	
reef grey	●	○	●	●	○	●	●	○	●	●	○	△	
black / beige	●	△	△	●	△	△	○	○	△	△	△	●	
black / red	●	○	●	●	△	○	●	○	△	●	△	△	
Edinburgh fabric (ELEGANCE)													
black	●	●	●	●	●	●	●	●	●	●	●	●	
savanna beige / cashmere beige	●	○	○	●	●	○	●	△	△	△	△	●	
reef grey	●	○	●	●	○	●	●	○	●	●	○	△	
Liverpool fabric / ARTICO man-made leather (AVANTGARDE and AMG sports package)													
black	●	●	●	●	●	●	●	●	●	●	●	●	
reef grey	●	○	●	●	○	●	●	○	●	●	○	△	
ARTICO man-made leather (CLASSIC, ELEGANCE)													
black	●	●	●	●	●	●	●	●	●	●	●	●	
savanna beige / cashmere beige ¹	●	○	○	●	●	○	●	△	△	△	△	●	
reef grey	●	○	●	●	○	●	●	○	●	●	○	△	
Leather (ELEGANCE, AVANTGARDE and AMG sports package)													
black	●	●	●	●	●	●	●	●	●	●	●	●	
savanna beige / cashmere beige ¹	●	○	○	●	●	○	●	△	△	△	△	●	
reef grey	●	○	●	●	○	●	●	○	●	●	○	△	
Leather (AVANTGARDE)													
black / sahara beige	●	○	○	●	○	●	●	○	○	△	△	●	
black / cognac brown	●	△	●	●	△	○	△	●	△	●	○	○	

● Recommended

○ Possible

△ Not recommended

¹ For ELEGANCE only

	C 200 CDI	C 220 CDI	C 320 CDI	C 320 CDI 4MATIC	C 180 KOMPRESSOR
No. and arrangement of cylinders	4 /in-line	4 /in-line	6/V	6/V	4 /in-line
Total displacement (cc)	2148	2148	2987	2987	1796
Rated output ¹ (kW at rpm)	100/3800	125/3800	165/3800	165/3800	115/5200
Rated torque ¹ (Nm at rpm)	270/1600–3000	400/2000	510/1600–2800	510/1600–2800	230/2800–4600
Compression ratio	17.5	17.5	17.7	17.7	9.3
Acceleration from 0 to 100 km/h (s) (automatic transmission)	10.4 (10.2)	8.5 (8.4)	7.7 (6.9)	– (6.9)	9.5 (9.9)
Top speed, approx. (km/h) (automatic transmission)	215 (213)	229 (227)	250 ² (250) ²	– (250) ²	223 (220)
Tyre size					
front	195/60 R 16	205/55 R 16	225/45 R 17	225/45 R 17	195/60 R 16
rear	195/60 R 16	205/55 R 16	225/45 R 17	225/45 R 17	195/60 R 16
Fuel	Diesel	Diesel	Diesel	Diesel	Premium unleaded
Fuel consumption ³ (l/100 km)					
urban (automatic transmission)	7.7–8.2 (9.0–9.2)	7.9–8.2 (9.1–9.2)	9.2–9.5 (10.0–10.3)	– (10.3–10.5)	10.5–10.7 (10.7–10.9)
extra-urban (automatic transmission)	4.5–4.9 (5.0–5.3)	4.7–4.9 (5.1–5.3)	5.5–5.8 (5.9–6.2)	– (6.2–6.6)	5.6–5.8 (5.8–6.0)
combined (automatic transmission)	5.7–6.1 (6.5–6.7)	5.9–6.1 (6.6–6.7)	6.9–7.2 (7.3–7.6)	– (7.7–8.0)	7.4–7.6 (7.6–7.8)
CO ₂ emissions ³ (g/km), combined (automatic transmission)	149 (171)	156 (173)	182 (193)	– (202)	177 (180)
Tank capacity (l)/incl. approx. reserve	66/8	66/8	66/8	66/8	66/8
Boot capacity (l)	475	475	475	475	475
Turning circle (m)	10.84	10.84	10.84	10.84	10.84
Kerb weight ⁴ (kg) (automatic transmission)	1560 (1575)	1585 (1605)	1700 (1700)	– (1760)	1485 (1500)
Permissible gross vehicle weight (kg) (automatic transmission)	2045 (2060)	2070 (2090)	2185 (2185)	– (2245)	1970 (1985)

¹ Figures according to Directive 80/1269/EEC in the currently applicable version ² Electronically governed ³ The figures shown were obtained in accordance with the prescribed measuring process (Directive 80/1268/EEC in the currently applicable version). The figures are not based on an individual model and do not constitute part of the product offer; they are provided solely for purposes of comparison between different vehicle models

C 200 KOMPRESSOR	C 230	C 280	C 280 4MATIC	C 350	C 350 4MATIC	C 63 AMG
4/in-line	6/V	6/V	6/V	6/V	6/V	8/V
1796	2496	2996	2996	3498	3498	6208
135/5500	150/6100	170/6000	170/6000	200/6000	200/6000	336/6800
250/2800-5000	245/2900-5500	300/2500-5000	300/2500-5000	350/2400-5000	350/2400-5000	600/5000
8.5	11.4	11.3	11.3	10.7	10.7	11.3
8.6 (8.8)	8.4 (8.6)	7.3 (7.2)	- (7.2)	- (6.4)	- (6.4)	- (4.5)
235 (230)	240 (233)	250 ² (246)	- (246)	- (250) ²	- (250) ²	- (250) ²
205/55 R 16	205/55 R 16	205/55 R 16	205/55 R 16	225/45 R 17	225/45 R 17	235/40 R 18
205/55 R 16	205/55 R 16	205/55 R 16	205/55 R 16	225/45 R 17	225/45 R 17	255/35 R 18
Premium unleaded	Premium unleaded	Premium unleaded	Premium unleaded	Premium unleaded	Premium unleaded	Super Plus
10.5-10.7 (11.0-11.2)	13.3-13.5 (13.1-13.3)	13.4-13.6 (13.3-13.5)	-(13.4-13.6)	-(13.9-14.2)	-(14.5)	-(20.9)
5.8-6.0 (6.1-6.3)	6.7-6.9 (6.8-7.0)	6.8-7.0 (6.9-7.1)	-(7.2-7.4)	-(7.3-7.6)	-(7.5)	-(9.2)
7.6-7.8 (7.9-8.1)	9.1-9.3 (9.1-9.3)	9.2-9.4 (9.2-9.4)	-(9.4-9.6)	-(9.7-10.0)	-(10.0)	-(13.4)
180 (187)	216 (217)	220 (219)	- (224)	- (232)	- (239)	- (319)
66/8	66/8	66/8	66/8	66/8	66/8	66/14
475	475	475	475	475	475	475
10.84	10.84	10.84	10.84	10.84	10.84	11.75
1490 (1505)	1540 (1560)	1555 (1575)	-(1635)	-(1610)	-(1670)	-(1730)
1975 (1990)	2025 (2045)	2040 (2060)	-(2120)	-(2095)	-(2155)	-(2170)

⁴ Figures according to Directive 92/21/EC, version 95/48/EC (kerb weight with fuel tank 90% full, driver, 68 kg, and luggage, 7 kg) for standard-specification vehicles. Optional extras and accessories will generally increase this figure and reduce the payload capacity accordingly

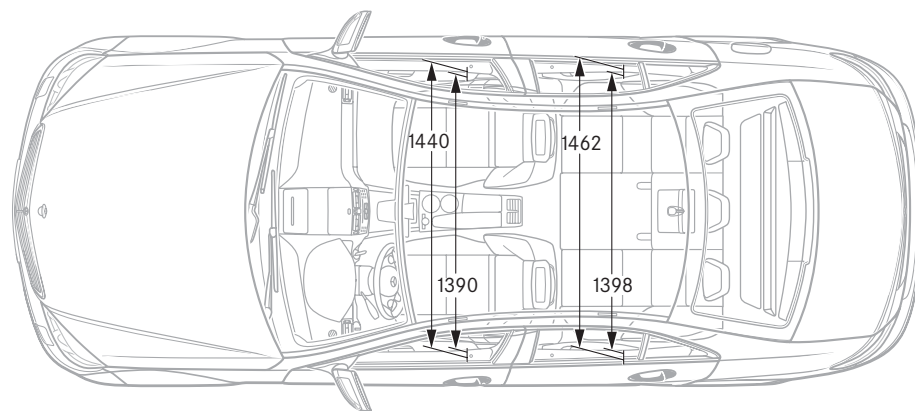
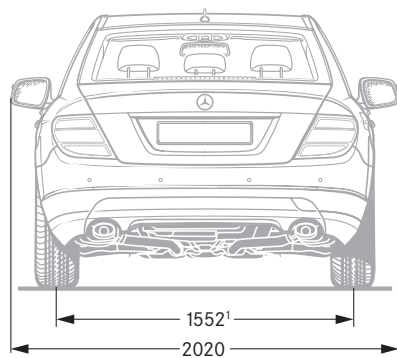
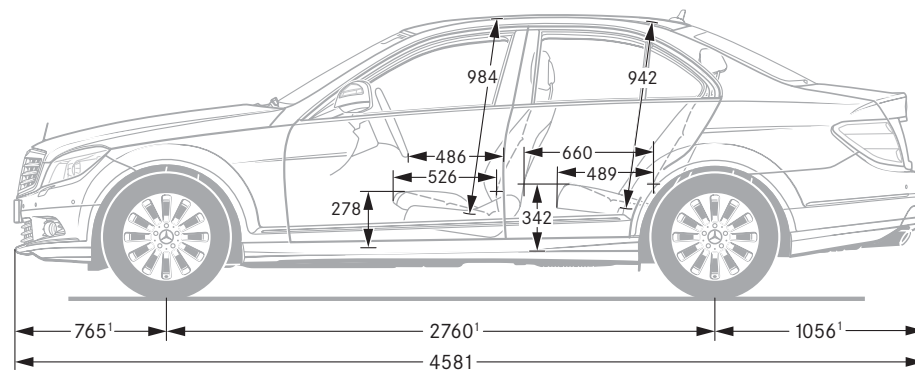
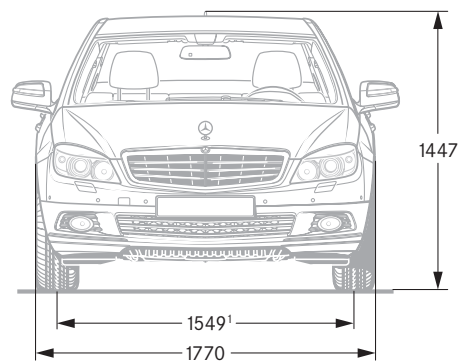

All measurements in millimetres. The dimensions shown are mean values and apply to standard-specification, unladen vehicles

¹ Carrying 3 people, each weighing 68 kg



	C 200 CDI	C 220 CDI	C 320 CDI	C 320 CDI 4MATIC
No. and arrangement of cylinders	4/in-line	4/in-line	6/V	6/V
Total displacement (cc)	2148	2148	2987	2987
Rated output ¹ (kW at rpm)	100/3800	125/3800	165/3800	165/3800
Rated torque ¹ (Nm at rpm)	270/ 1600–3000	400/2000	510/ 1600–2800	510/ 1600–2800
Compression ratio	17.5	17.5	17.7	17.7
Acceleration from 0 to 100 km/h (s) (automatic transmission)	10.8 (10.6)	8.9 (8.8)	7.9 (7.1)	– (7.1)
Top speed, approx. (km/h) (automatic transmission)	208 (204)	224 (220)	245 (244)	– (244)
Tyre size front	205/55 R 16	205/55 R 16	225/45 R 17	225/45 R 17
rear	205/55 R 16	205/55 R 16	225/45 R 17	225/45 R 17
Fuel	Diesel	Diesel	Diesel	Diesel
Fuel consumption ³ (l/ 100 km)				
urban (automatic transmission)	7.9–8.1 (9.0)	8.1 (9.2)	9.7–10.0 (10.2–10.5)	– (10.4–10.07)
extra-urban (automatic transmission)	4.8–5.0 (5.3)	4.9–5.0 (5.3–5.5)	5.9–6.2 (6.2–6.5)	– (6.3–6.6)
combined (automatic transmission)	6.0–6.1 (6.7)	6.1 (6.8)	7.1–7.4 (7.5–7.8)	– (7.8–8.1)
CO ₂ emissions ³ (g/km), combined (automatic transmission)	157 (176)	159 (178)	188 (199)	– (205)
Tank capacity (l)/incl. approx. reserve	66/8	66/8	66/8	66/8
Boot capacity (l)	485	485	485	485
Turning circle (m)	10.84	10.84	10.84	10.84
Kerb weight ⁴ (kg) (automatic transmission)	1605 (1615)	1630 (1650)	1750 (1750)	– (1810)
Permissible gross vehicle weight (kg) (automatic transmission)	2135 (2145)	2160 (2180)	2280 (2280)	– (2340)

¹ Figures according to Directive 80/1269/EEC in the currently applicable version ²Electronically governed ³The figures shown were obtained in accordance with the prescribed measuring process (Directive 80/1268/EEC in the currently applicable version). The figures are not based on an individual model and do not constitute part of the product offer; they are provided solely for purposes of comparison between different vehicle models

C 180 KOMPRESSOR	C 200 KOMPRESSOR	C 230	C 280	C 350	C 63 AMG
4/in-line	4/in-line	6/V	6/V	6/V	8/V
1796	1796	2496	2996	3498	6208
115/5200	135/5500	150/6100	170/6000	200/6000	336/6800
230/2800-4600	250/2800-5000	245/2900-5500	300/2500-5000	350/2400-5000	600/5000
9.3	8.5	11.4	11.3	10.7	11.3
9.8 (10.2)	8.8 (9.0)	8.6 (8.9)	7.5 (7.5)	- (6.5)	- (4.6)
218 (215)	228 (225)	232 (227)	242 (240)	- (250) ²	- (250) ²
205/55 R 16	205/55 R 16	205/55 R 16	205/55 R 16	225/45 R 17	235/40 R 18
205/55 R 16	205/55 R 16	205/55 R 16	205/55 R 16	225/45 R 17	255/35 R 18
Premium unleaded	Premium unleaded	Premium unleaded	Premium unleaded	Premium unleaded	Super Plus
10.7-10.8 (11.2-11.3)	10.7-10.9 (11.2-11.4)	13.4-13.6 (13.4-13.6)	13.6-13.8 (13.4-13.6)	- (14.5-14.8)	- (21.1)
5.9-6.0 (6.3-6.4)	6.0-6.2 (6.4-6.6)	6.9-7.1 (6.9-7.1)	7.0-7.2 (7.1-7.3)	- (7.3-7.6)	- (9.5)
7.7-7.8 (8.1-8.2)	7.8-8.0 (8.1-8.3)	9.3-9.5 (9.3-9.5)	9.4-9.6 (9.4-9.6)	- (9.9-10.2)	- (13.7)
183 (192)	184 (193)	221 (221)	224 (224)	- (235)	- (326)
66/8	66/8	66/8	66/8	66/8	66/14
485	485	485	485	485	485
10.84	10.84	10.84	10.84	10.84	11.75
1535 (1550)	1540 (1555)	1585 (1605)	1600 (1615)	- (1655)	- (1795)
2065 (2080)	2070 (2085)	2115 (2135)	2130 (2145)	- (2185)	- (2275)

⁴ Figures according to Directive 92/21/EC, version 95/48/EC (kerb weight with fuel tank 90% full, driver, 68 kg, and luggage, 7 kg) for standard-specification vehicles. Optional extras and accessories will generally increase this figure and reduce the payload capacity accordingly

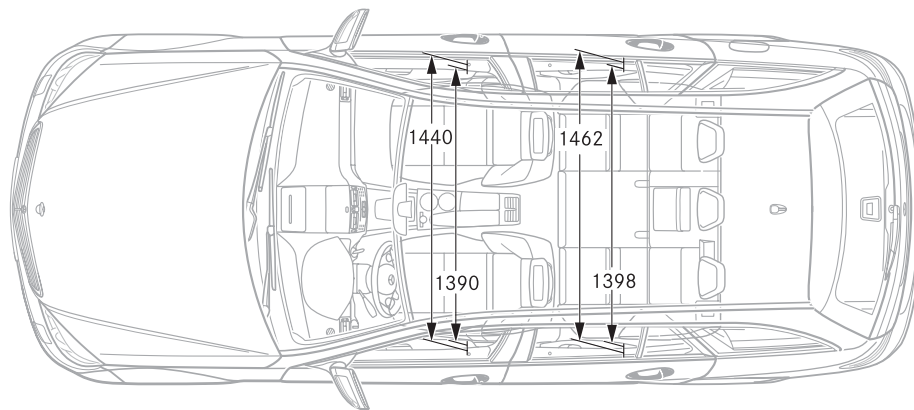
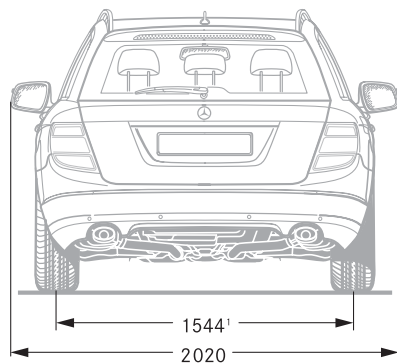
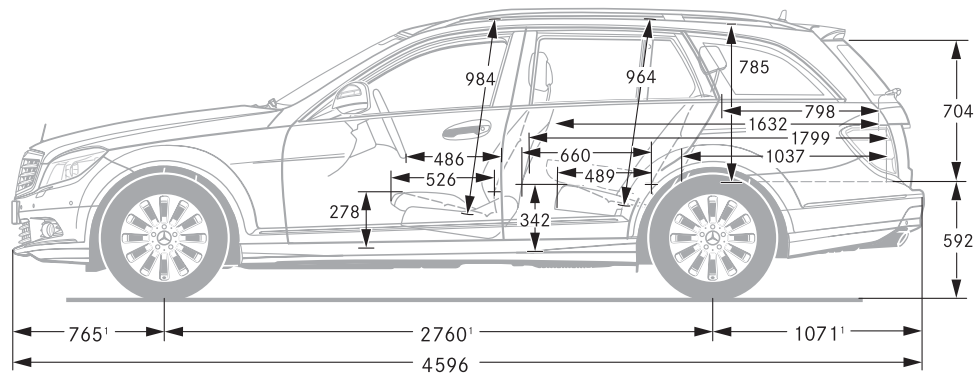
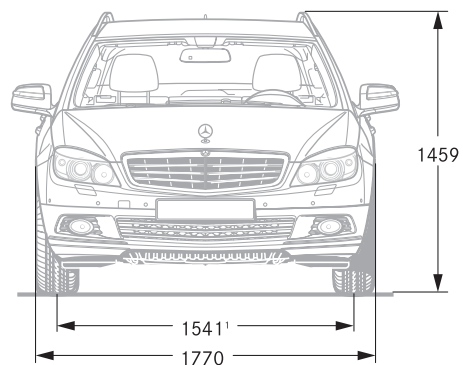

All measurements in millimetres. The dimensions shown are mean values and apply to standard-specification, unladen vehicles.

¹ Carrying 3 people, each weighing 68 kg



The best places to go star-gazing

The world of Mercedes-Benz: our Centres, our dealerships, the Museum and MercedesCard

Experience Mercedes-Benz at first hand

It all started in Berlin at the end of 2000: the concept of the car dealership was reinvented with the opening of the first Mercedes-Benz Centre. Featuring the entire Mercedes-Benz model line-up as well as the accessories range, brand merchandise and an attractive programme of events. Centres have now opened in many large European cities, offering a welcoming environment in which to experience the brand at first hand.

But it's not just in major cities that you can experience the legendary Mercedes-Benz brand and service. A close-knit network of company-owned branches and authorised dealers ensures that you are never far from the wide range of services, the comprehensive customer care and the high quality which you expect from Mercedes-Benz. And you can count on their support at every stage – before you buy your Mercedes, during the purchase process and, most importantly, for a long time afterwards, too.

Mercedes-Benz Museum

More than 120 years of automotive history in one place – the Mercedes-Benz Museum in Stuttgart-Untertürkheim. With a total exhibition area of 16,500 square metres, it transports the visitor into a fascinating world of automotive achievement. You can see the first modern motor car, the Mercedes Simplex, discover over 100 years of motor-racing history, and, of course, admire our classics, such as the Gullwing and the “Tail Fin”. Legendary cars such as these have always occupied a special place in the hearts of car enthusiasts. Now they have a special place of their own in the Mercedes-Benz Museum. We look forward to welcoming you there soon.

MercedesCard

There's also a wealth of experiences to enjoy when you're not at the wheel of your Mercedes-Benz. Owning a MercedesCard is all it takes. It acts as your ticket to the world of Mercedes-Benz and is a practical credit card at the same time. Answer

the annual questionnaire and we'll even waive the card fee. The MercedesCard Journal contains details of sporting, travel and cultural events as well as attractive new products selected exclusively for you. Articles on all aspects of the Mercedes-Benz brand can be found in the Mercedes magazine. What's more, your MercedesCard automatically gives you free admission to the Mercedes-Benz Museum. Not only does the MercedesCard offer excitement, it also provides peace of mind: the Mercedes-Benz/MercedesCard insurance package ensures that practically every eventuality is covered.

Details of the full range of MercedesCard services as well as application forms can be found at www.mercedes-benz.de/mercedescard

Information about the MercedesCard in Austria and Switzerland can be found on the Mercedes-Benz websites for these countries.

Owning a Mercedes is even more reassuring than you might think

Service24h and the financial services offered by DaimlerChrysler Bank

24-hour service

One thing that will always accompany you in your new Mercedes is a feeling of reassurance. Because MercedesBenz Service24h is there for you around the clock, 365 days a year. In the very unlikely event of a technical breakdown or starting problem anywhere in Europe, you can rely on round-the-clock assistance from MercedesBenz Service24h. Simply phone our Service hotline on 00800 1 777 7777* and our specialists will immediately organise fast, professional assistance. Anytime, 365 days a year, 7 days a week, 24 hours a day. As soon as your call is received, a member of our

Service24h team will be dispatched to your location. Often the problem can be rectified on the spot, but if this is not possible, we will naturally ensure that your vehicle is taken to the nearest Mercedes-Benz workshop and get you back on the road as quickly as possible.

*In non-affiliated European countries:
+49 69 953 07 27

DaimlerChrysler Bank

If you have already set your heart on your dream Mercedes and want to remain flexible in financial terms, you may be interested in our range of

financial services. Our single-source leasing, financing, insurance and service packages could be exactly what you're looking for. The on-line calculator allows you to work out your monthly payments for yourself. In addition to individually geared financial services, we can also offer you tailor-made investment products, including an instant-access savings account, fixed-interest investments and portfolio funds. For further information, call us on 0 18 03-DC BANK or 0 18 03-32 2265 (9 ct/min), or visit:

www.daimlerchrysler-bank.de



A Mercedes-Benz C-Class is at its most impressive on the road. It is only here that you can appreciate the effortlessly superior driving experience which makes this car so special. Feel the pull of the powerful engine and enjoy the superb precision of the steering response.

It is impossible for this brochure to convey the special atmosphere that you feel when driving a Mercedes-Benz C-Class. You have to experience it in order to understand it. That is why we warmly invite you to take a test drive. You can use the dealership search function at www.mercedes-benz.com to locate your nearest Mercedes-Benz dealer who will be delighted to arrange one for you.

To be continued. With a test drive

Take-back of end-of-life vehicles. Coming full circle

At the end of its long life, you can return your C-Class to us for environment-friendly disposal in accordance with the EC End-Of-Life Vehicle Directive¹. But that day lies a long way off.

¹ Applies in accordance with national regulations to vehicles up to 3.5 tonnes gross weight. Mercedes-Benz passenger cars have met the statutory regulations governing the suitability of their design for reuse and recycling for a number of years now. A network of vehicle take-back depots and dismantlers has been established which will process your vehicle in an environment-friendly manner. The ways in which both vehicles and parts can be recovered are subject to ongoing development and improvement. Consequently, the C-Class will be able to comply with any future increases in the recycling quota within the stipulated time limits. For further information please call 00800 1 777 7777.

Please note: changes may have been made to the product since this brochure went to press (31.08.2007). The manufacturer reserves the right to make changes to the design, form, colour and specification during the delivery period, provided these changes, while taking into account the interests of the vendor, can be deemed reasonable with respect to the purchaser. Where the vendor or the manufacturer uses symbols or numbers to describe an order or the subject of an order, no rights may be derived solely from these. The illustrations may show accessories and items of optional equipment which are not part of standard specification. Colours may differ slightly from those shown in the brochure, owing to the limitations of the printing process. This brochure has been compiled by DaimlerChrysler AG of Germany and is distributed internationally. It provides a general indication of the range of models, features, optional extras and/or colours available in various countries. Some of the models, features, optional extras and/or colours may not be available in your country, or may only be available in a different specification. Additionally some models, features, optional extras and/or colours may only be available in combination with others. For current and more specific information in relation to the range of models, features, optional extras and/or colours available in your country, and their pricing, you should contact your nearest authorised Mercedes-Benz Passenger Car Dealer.
www.mercedes-benz.com