



THE G-CLASS



Mercedes-Benz

The G-Class	12	My G-Class	42
VARIANTS	14	EQUIPMENT	44
<hr/>		Standard equipment	46
DRIVING REFINEMENT		Light-alloy wheels	52
Petrol engines	16	Optional extras	54
Diesel engine	18	<hr/>	
Transmissions	20	COLOURS AND MATERIALS	
Frame and chassis	22	Paintwork	60
<hr/>		Leather and upholstery	64
ON-ROAD/OFF-ROAD SYSTEMS	24	Wood	70
<hr/>		Possible combinations	71
COMFORT		<hr/>	
Cockpit	28	TECHNOLOGY	
Interior	30	Technical data	72
<hr/>		Dimensions	73
SAFETY	34	<hr/>	
<hr/>		SERVICES	76
AMG			
G 55 AMG	38		
AMG equipment	40		

Your destination: the horizon

The G-Class

Dynamism. Safety. Comfort. These are the classic attributes that transform a car into a Mercedes-Benz. And the G-Class – our classic off-roader – is no exception. The G-Class offers a unique take on these hallmark Mercedes-Benz attributes, even in the world's most remote locations where few vehicles make the grade.

The G-Class began its incredible journey back in 1979. Countless technical improvements, modernisation measures and model variants have been introduced over the years. Yet its unique character remains firmly intact.

On the following pages, we bring you the next stage of this journey. Follow the further-refined G-Class as it heads for new horizons. And discover how one of the classics in automotive history is shining in a new light.















The G-Class







One legend. Several incarnations

All good things come in threes: the G-Class variants

The character of the G-Class has barely changed over the years. And why should it? After all, its distinctive form is a true design classic. Robust. Functional. Timeless.

Like every legend, the classic G-Class off-roader gives customers a choice of versions. From the prestigious long Station Wagon and the short Station Wagon to the Cabriolet, the latter being the only one of its kind world-wide in this vehicle category.

In addition to these different body variants, there is also an AMG version of the long Station Wagon available. In terms of both looks and performance, this AMG model is quite simply in a class of its own (see AMG section starting on page 38).

As is the case with so many legends, the different versions all have one core aspect in common: a licence to thrill.



On-road performance you just know will translate into off-road capability

Masters of every situation: the G-Class petrol engines

When you settle into your seat in a G-Class, you notice the difference immediately. The elevated sitting position and the outstanding all-round visibility provide a clear indication of what is in store: a ride on board the G-Class is something very special indeed.

When you fire the engine of the G 500, you notice that there is also something really special beneath the bonnet: the tried-and-trusted 5-litre V8 powerplant is perfectly configured to meet the demands of this multi-faceted off-roader.

Featuring electronic petrol injection, three valves per cylinder and electronic mapped dual ignition, it ensures effortlessly superior power delivery every time. And with 296 hp (218 kW) on tap, it makes equally light work of difficult terrain or simple overtaking – an attribute that is clearly shared by the second petrol powerplant in the G-Class range: the AMG V8 supercharged engine. Find out more about this starting on page 38.

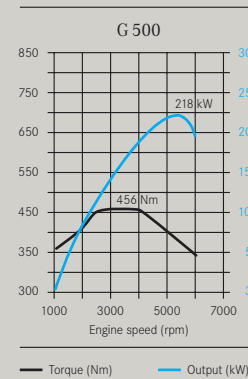

G 500

The G 500 achieves its peak torque of 456 Nm across a broad engine speed range from 2800 rpm to 4000 rpm

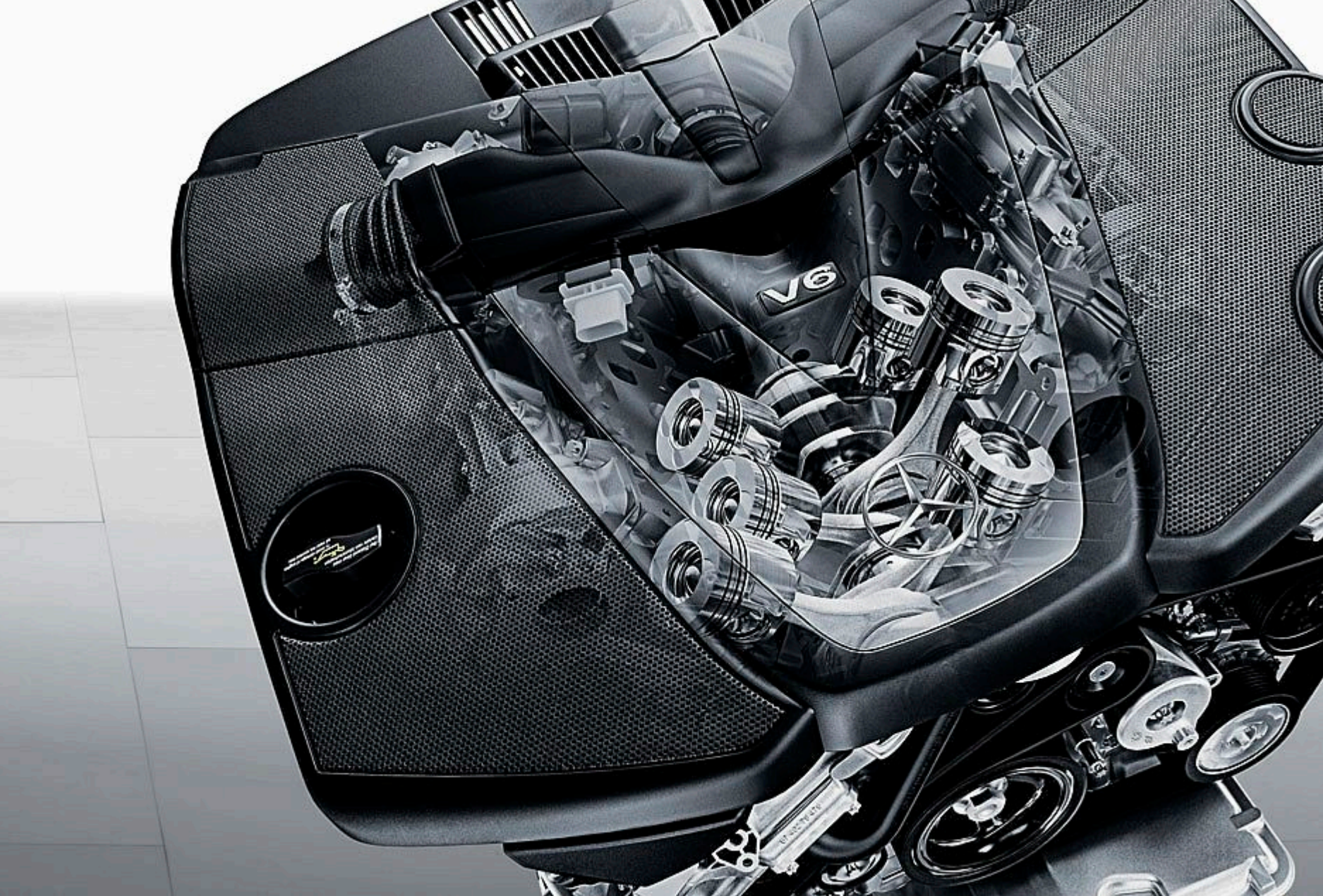

An exhilarating drive with an added bonus

Smooth and powerful: the CDI diesel engine

As well as being an impressive performer, the high-torque diesel engine is highly economical. Seldom has a genuine off-roader provided such a compelling mix of power and efficiency, as reflected in the extremely respectable fuel-consumption figures.

The V6 common-rail diesel engine with particulate filter serves up an exciting blend of refinement and performance. Even at low revs,

for example when driving slowly off-road or negotiating steep uphill gradients, it is still capable of developing its maximum output.

The standard-fit fuel filter with water separator provides highly effective protection against dirt build-up in your G 320 CDI. For a long diesel life.

G 320 CDI

The 3-litre V6 diesel engine achieves its maximum output of 224 hp (165 kW) at just 3800 rpm

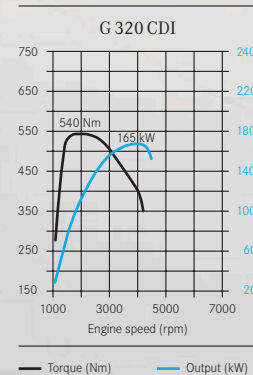

The more fluid the movement, the better the performance

The G-Class automatic transmissions

Sports stars hone their movements to perfection over a period of years, their theory being that smooth, fluid movements make for outstanding performance.

Inspired by this, the Mercedes-Benz engineers have developed an extremely fluid sequence of movements for the standard-fit 7G-TRONIC automatic transmission in the G 320 CDI and G 500. The gear changes are barely perceptible – even when a gear is skipped, as is necessary on occasions. So you are always in the right gear, leaving you to enjoy the superlative handling and quiet ride.

The G 55 AMG features the tried-and-trusted 5-speed automatic transmission which transfers the immense power and high torque of the AMG engine to the wheels with consummate ease.

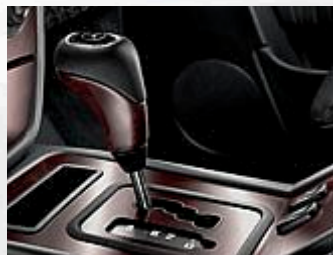

SELECTOR LEVER

Smooth shifts every time:
the wood/leather selector lever
with Mercedes-Benz badge

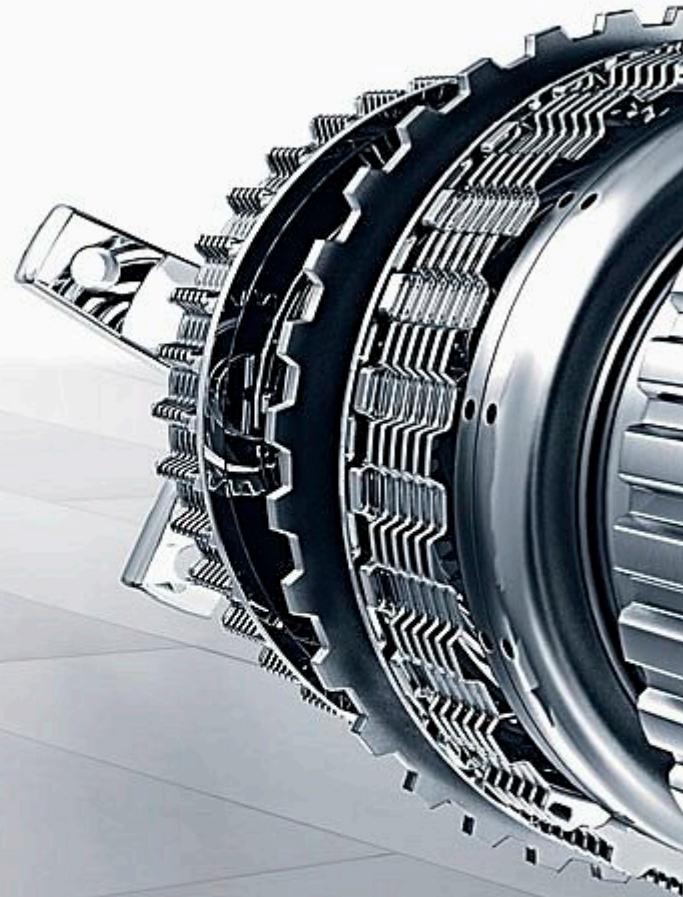

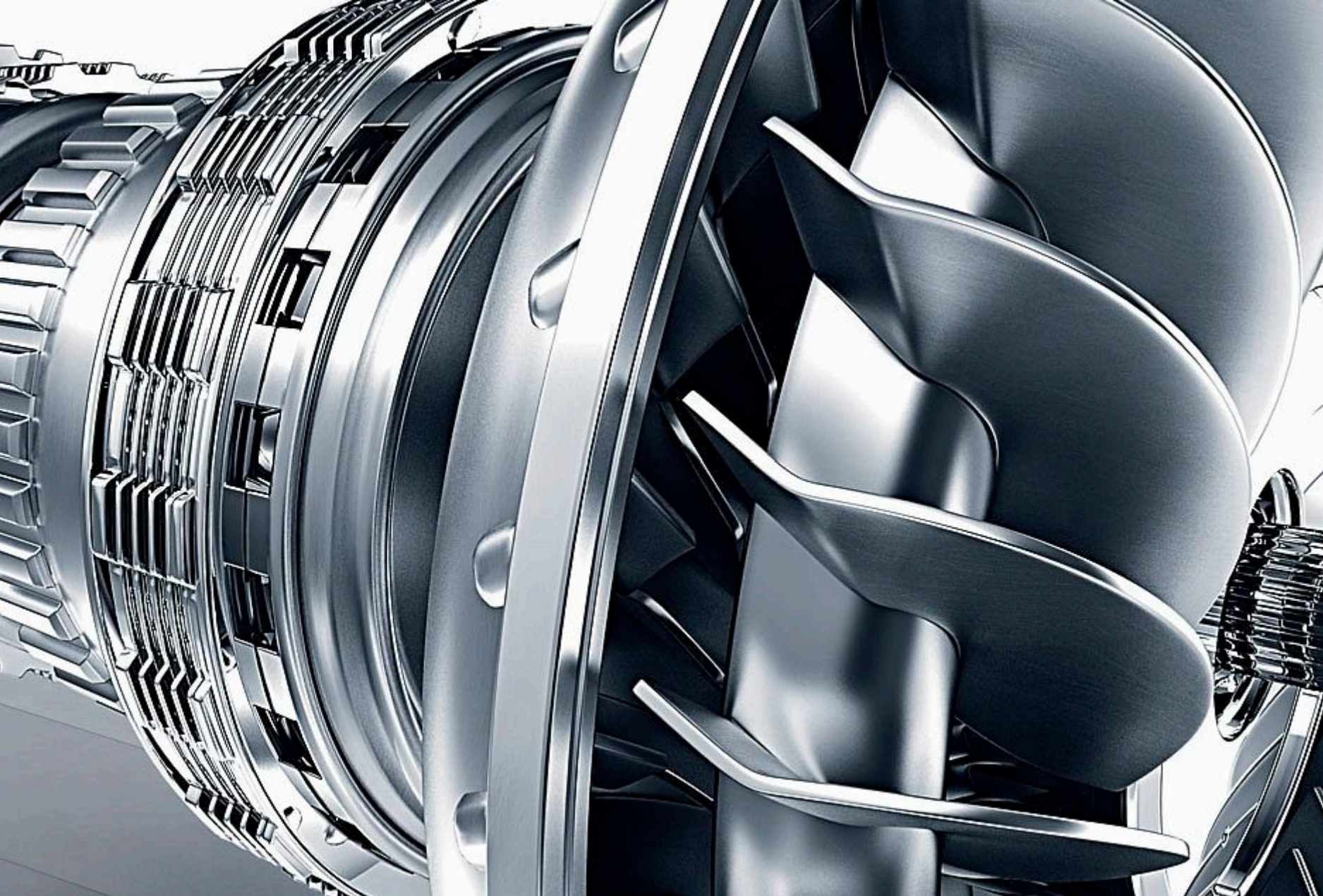

Tested to overcome any challenge

Frame and chassis configured for maximum performance

When building a G-Class, we leave nothing to chance. After all, longevity and value retention are key quality features that are a source of great pride to us.

Up to 4 mm thick in places, the G-Class frame is held together by more than 6400 weld spots. As well as that, it is galvanised and waxed. The vehicle floor, meanwhile, has an additional plastic coating. And all attachments undergo thorough treatment in an electro dip-priming process before having several coats of paint applied. This level of protection leaves hardly any of the G-Class' surfaces open to attack by water, snow, road salt or even desert sand.

It is off the road that the G-Class faces its stiffest challenges. It prepares for these on our special off-road test tracks. This is where the G-Class takes its driving test before moving on to a final examination on the road. In tough off-road conditions, two precisely located rigid axles with high lift and long spring travel provide the necessary ground clearance and outstanding traction so that maximum power can be channelled through the permanent all-wheel-drive system.



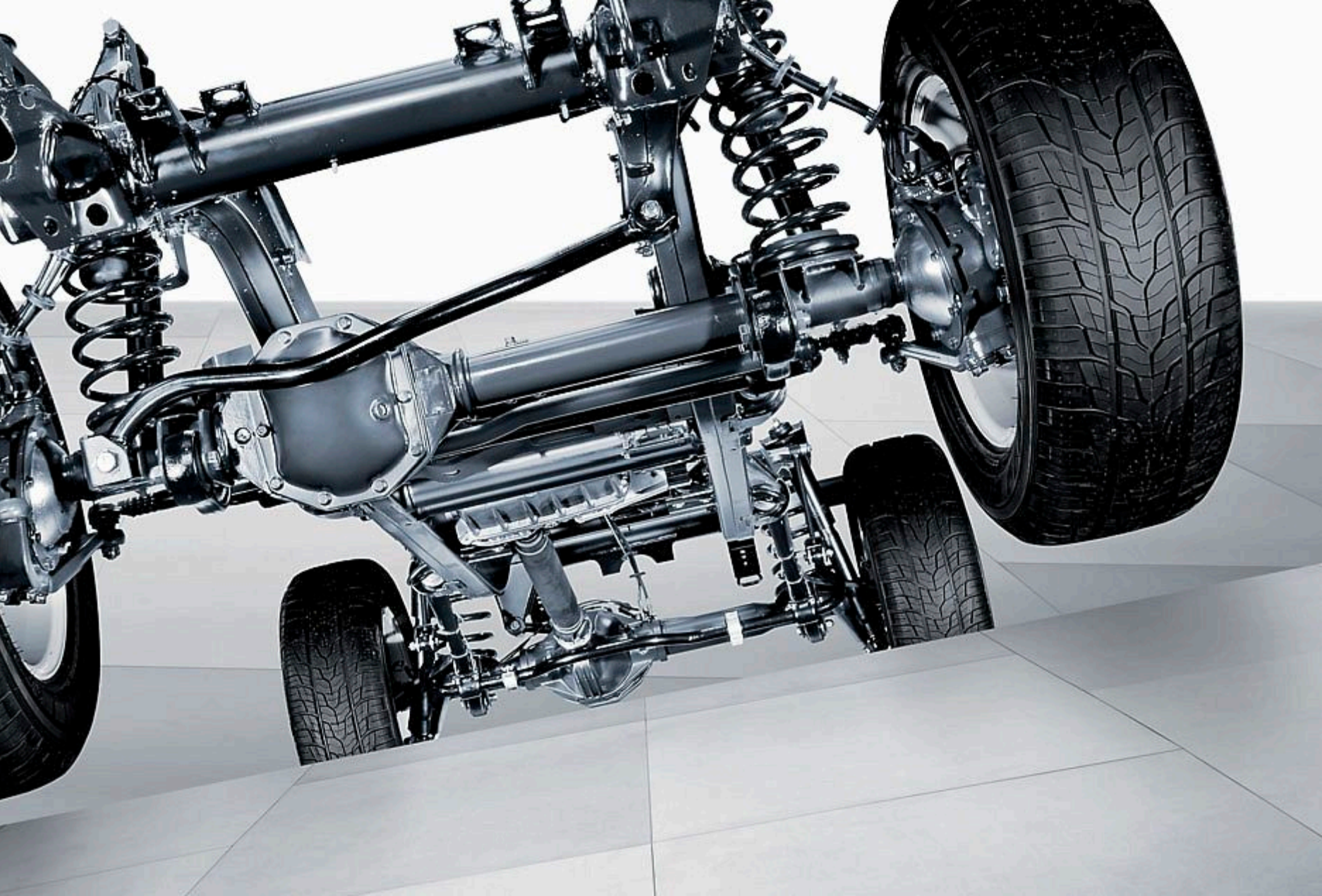

On-road/off-road systems

Power meets intelligence

Low-range ratio and traction system in the G-Class

Brute force alone does not make for smooth progress in difficult conditions. For this you need immense power with intelligent control. Driver aside, it is the 4ETS electronically controlled traction system that assumes this task in the G-Class, sending precisely the right amount of engine power to the wheels that currently offer the best traction, making it much easier to maintain control on snow- or ice-covered surfaces.

The driver receives additional assistance courtesy of the transfer case's off-road ratio – specified as standard. One press of the low-range switch is all it takes to activate this feature. At low speed and with maximum traction, the G-Class overcomes obstacles with ease. It climbs, clambers and scrambles but, above all, it demonstrates just what it takes to be a truly great off-roader.

Greater ride stability thanks to 4ETS

If up to three wheels have poor grip, they are braked by 4ETS. The tractive power is then directed to the wheels offering better grip

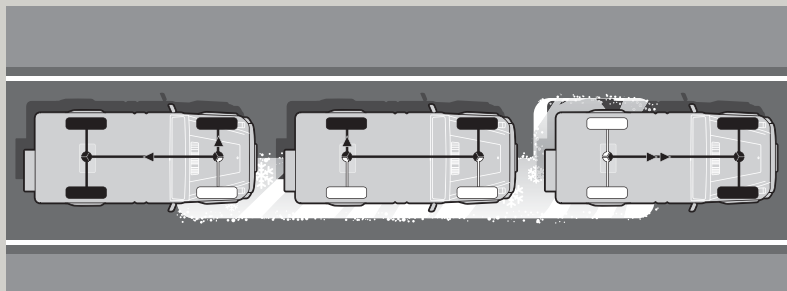



Go over the next patch of scree. Then turn left into the river bed

Fully lockable differential locks for full-on off-road driving

Teamwork simply makes it easier to achieve great things. This is why everything works together in the G-Class. For example, the permanent all-wheel drive, the 4ETS Electronic Traction System, the synchromesh transfer case and the three fully lockable differential locks. This teamwork is one of the outstanding features of the G-Class. It is what makes it a true off-roader. No other vehicle comes close to offering such a unique combination of attributes.

Fitted as standard, the three differential locks can be activated individually and in a logically specified sequence. So you can be sure that the G-Class adapts perfectly to its surroundings. If a wheel loses traction, the power is redirected to the wheels offering the best grip. Even if only one wheel is providing grip, your G-Class will still make good headway – an impressive achievement and just what you need when driving off-road.









One star at the front. Five stars inside

Neat, comfortable and innovative: the interior

A vehicle displaying the Mercedes star is a sure-fire bet when it comes to outstanding quality and workmanship. Nowhere is this more impressively apparent than in the interior of the G-Class.

The generous feeling of spaciousness imparts a sense of freedom. And that's before the G-Class has even started moving. What's more, the hallmark, elevated sitting position ensures excellent all-round visibility at all times, while the cockpit is designed with ease of operation firmly in mind.

You experience the comfort and convenience of a G-Class the second you open the doors and again when you close them. Attention to detail

takes pride of place. As you will see when you grasp the fine-leather-trimmed steering wheel which, of course, swings upwards once you have parked, to make getting out even easier. A service that merits five stars all of its own.

On the following pages you can familiarise yourself with the G-Class equipment and appointments. Plus we will show you how to create your own individual G-Class (page 54 onwards).

All under control
The multifunction steering wheel is available as standard in leather (G 320 CDI) or wood/leather (all V8 models)





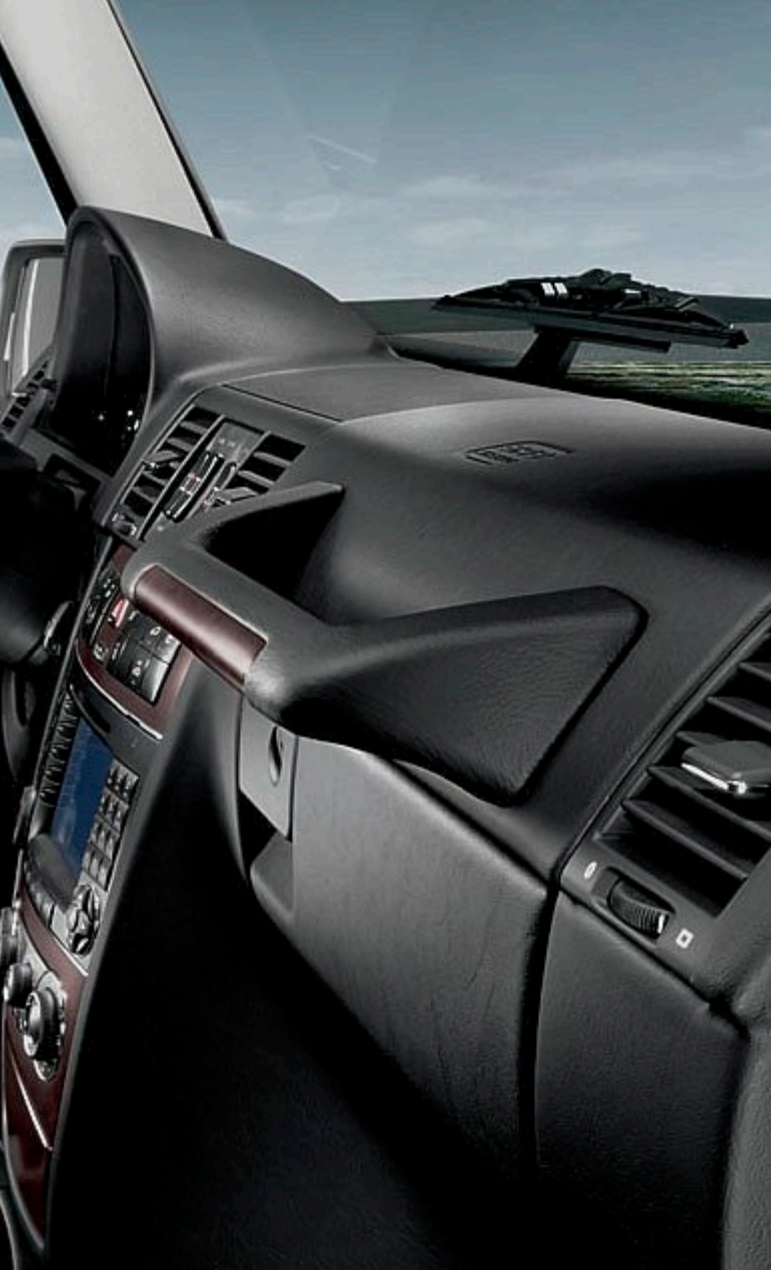

The drive just can't last long enough

First-class travel: seat comfort in the G-Class

After a long drive in the G-Class, it's hardly surprising that many want to stay seated a while longer. That's because these seats leave practically nothing to be desired.

The front seats adjust electrically, allowing you to select your preferred seat position and height. And, as you would expect from a vehicle such as the G-Class, the standard specification includes heated seats as well as an armrest between the front seats with a stowage compartment and a cup holder. So there will be no complaints if a ride on board the G-Class occasionally lasts a little longer.

The G-Class takes your desire for freedom very seriously

A choice of seating configurations and a large load compartment

Drivers who opt for a genuine off-roader generally have a burning desire for freedom. And the G-Class interior caters to this desire, offering a wealth of space and a choice of seating configurations. From two-seater to seven-seater (long Station Wagon), almost everything is possible in and with a G-Class. What's more, the load compartment's capacity of up to 2250 litres provides plenty of room even for a round-the-world trip, let alone a visit to the golf course. Just as you prefer.

For those who want even more space, the engine and chassis configuration allows a trailed load of up to 3.5 t. Whether you are towing a yacht, a horsebox or a caravan, the G-Class grants you safe passage almost regardless of the load and terrain.

Room for your ideas
With side-facing bench seats (optional extra), there is easily enough room for up to seven people on board the long Station Wagon

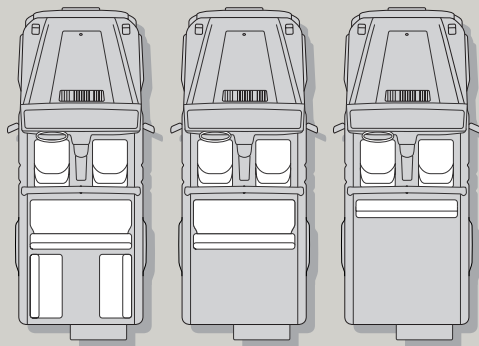





A safe bet for even the most intrepid of explorers

On-board safety technology – from Mercedes-Benz

We laid the first milestone back in the 1950s with the invention of the safety passenger cell. Since then Mercedes-Benz engineers have come up with further safety-enhancing innovations year after year. And many of them feature in the G-Class.

They help to detect and control critical situations on and off the road in plenty of time. And they include numerous pre-crash preventive protection measures. And should an accident occur, a whole host of passive safety features can be activated. So you can sit back and relax: with a G-Class the focus is on adventure rather than risky venture.





Companions you can count on

Safety-enhancing electronic assistance systems

When you take the wheel of a G-Class, you have already delegated some of the key tasks, thanks to a whole host of reliable electronic aids which are activated immediately in critical situations. If there is a risk of the G-Class skidding, for example, the Electronic Stability Program (ESP®) kicks in immediately. It restricts the engine torque, applies the brakes at one or more wheels and thus stabilises the vehicle.

In the event of an emergency stop, Brake Assist (BAS) provides the necessary brake pressure whilst at the same time assisting the anti-lock braking system (ABS) which has been developed and modified especially for the G-Class. This means that the driver can remain in control of the vehicle at all times, even in critical situations.

These electronic aids, coupled with the passive safety features, ensure a high level of protection for the vehicle occupants.

AMG

AMG: absolute motoring genius

The G 55 AMG engine

AMG. Three magical letters that are synonymous with performance, prestige and passion. Each engine is produced by a single engineer who has a wealth of experience. They even put their signature on the engine tag. So you can be sure that the 5.5-litre V8 supercharged engine at the heart of your G 55 AMG will continue to perform sterling service for many years to come.

Developing 500 hp (368 kW), the powerplant propels the G 55 AMG from 0 to 100 km/h in 5.5 seconds. This superlative power delivery combines with the agile handling dynamics to provide a scintillating level of performance that is matched only by the sound of the large-displacement V8, while the AMG high-performance brakes bring the vehicle to a halt quickly and safely.

Likewise the chassis of the G 55 AMG has been configured for sporty performance without restricting the vehicle's off-road capabilities. AMG specifications include harder shock absorbers, for example.

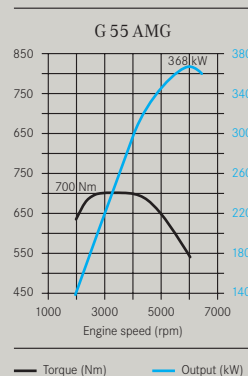

Full power ahead

The impressive torque of 700 Nm is available across a broad engine speed range from 2570 rpm to 4000 rpm



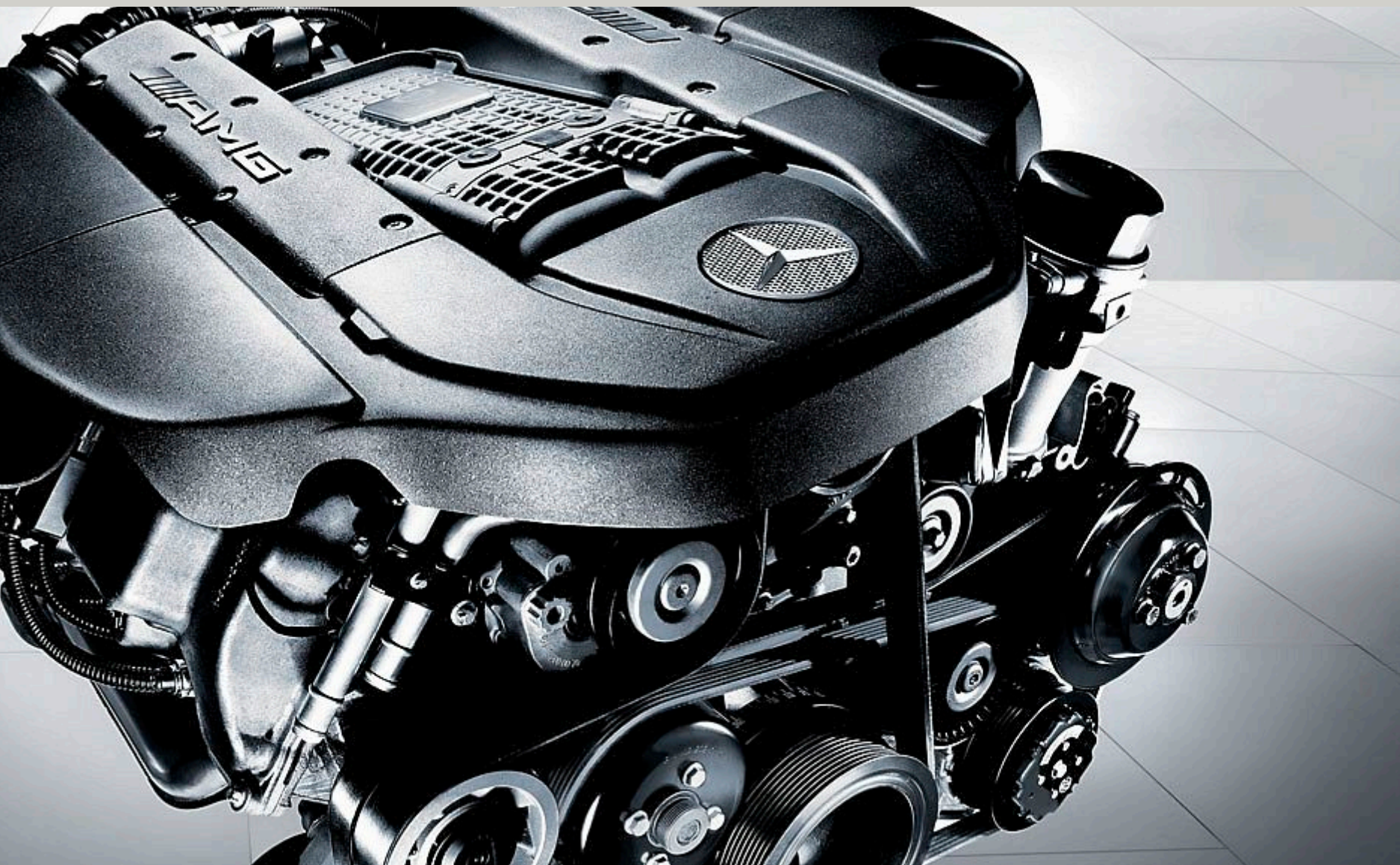

AMG: take it to the limit

The equipment for the G 55 AMG

With its distinctive exterior, the G 55 AMG cuts a fine figure wherever it goes. Both on the road or way off it.

It features exciting, extravagant bodystyling – an AMG hallmark – including 18-inch light-alloy wheels, the AMG exhaust system with twin side-venting tailpipes, flared wheel arches and a silver-painted radiator grille. Moving inside, the AMG-specific instrument cluster, illuminated stainless-steel door sill panels and G 55 lettering on the selector lever underline this extraordinary vehicle's sporting credentials.

Specialists also designed the designo leather appointments and the designo wood trim elements. These refined styling features are taken from the designo range, which offers you a whole host of individualisation options for your G 55 AMG.

Exhaust pipes



Instrument cluster







My G-Class





With the G-Class, you're off to an ideal start

Extensive range of equipment options for the G-Class

Perhaps the most impressive aspect of the G-Class' evolution is the level of equipment. That's because what initially started out as an off-roader for the purists has long been specified with all the creature comforts that people have come to expect from a Mercedes-Benz.

Even the standard-specification G-Class features numerous extras. The THERMATIC automatic climate control, for example, sets precisely the interior temperature you require. Then there are the state-of-the-art audio systems which deliver sound quality par excellence – the Audio 20 radio in the G 320 CDI or the COMAND APS control and display system in the G 500 and G 55 AMG.

The range of optional extras available allows you to create just the G-Class you want. The reversing camera in conjunction with the ultrasonic reversing aid and the garage door opener integrated in the interior mirror are just two of the many other comfort- and convenience-enhancing equipment options available for your G-Class.



No darkness, only light

The G-Class lighting concept

The distinctive face of the G-Class is characterised by clean-cut surfaces and straight lines. The hallmark circular headlamps have always provided a striking contrast to this. Featuring state-of-the-art bi-xenon technology, they illuminate a wide area of the road brightly, enabling you to see dangers and obstacles well in advance.

Additional fog lamps with an integrated cornering light function light up the road immediately in front of the vehicle and illuminate bends.

At the rear as at the front, the G-Class shines with an impressive light system including oval tail lights with a sophisticated LED look and the hallmark rectangular light clusters.

The exterior mirrors round off the lighting concept, with standard features including integrated indicators and front area lighting. What's more, they are electrically adjustable, heated and automatically dimming, assuring you a clear view of other traffic at all times.

Exterior mirrors



Bi-xenon headlamps



Tail light





Adaptability: the G-Class caters to your needs

Clear and practical: the G-Class controls and memory function

Everything in the G-Class can be controlled simply and intuitively: from the exterior mirrors to the central locking. This is not only practical and convenient, it also enhances safety at critical moments.

Clear indicators and functional controls quickly enable drivers to familiarise themselves with the

“G” – the automatic climate control system, for example, is extremely easy to use.

The standard equipment package for the G-Class also provides for infinitely variable adjustment and storing of the seat, head-restraint, steering-wheel and exterior-mirror positions for up to three people.

One press of a button is all it takes for the G-Class to find your preferred settings. Making it entirely your own G-Class once more.

Air-conditioning controls



Memory function





Inner values matter to the G-Class

The interior: cleverly thought-out equipment and appointments coupled with timeless design

Clear, puristic lines lend the exterior of the G-Class its distinctive appearance. And there is a natural continuation of this design philosophy in the classically modern interior.

Beneath the pristine surface, however, lies state-of-the-art Mercedes-Benz technology: from the multifunction steering wheel to the sophisticated navigation system (standard for the G 500 and G 55 AMG).

Standard equipment for the G 320 CDI includes the high-tech Audio 20 radio, while the range of audio options for the long Station Wagon includes a harman/kardon sound system with 10 high-end loudspeakers.

But it's not just the technical equipment that displays the inner values of the G-Class. So do the stylishly incorporated fine-wood and chrome trim elements that give the passenger compartment the perfect finishing touches.

Audio 20 radio



Door sill panel



Differential lock buttons



STANDARD EQUIPMENT (SELECTION)

7G-TRONIC 7-speed automatic transmission/5-speed automatic transmission in the G 55 AMG

12-volt sockets in front passenger footwell, rear and load compartment

Airbags for driver and front passenger, long Station Wagon also features windowbags

AMG light-alloy wheels, painted titanium grey²

Anti-lock braking system (ABS) and Brake Assist (BAS)

Armrest between front seats with stowage compartment and cup holder

ASSYST service interval indicator

Belt tensioners on front seats

Bi-xenon headlamps

Cabriolet soft-top, black, electrohydraulically operated

Central locking with infrared remote control and interior switch

COMAND APS control and display system^{1,2}/Audio 20 CD radio³

Cruise control with variable speed limiter

Differential locks (transfer case, front and rear axle)

Electronic brake force distribution (EBD)

Electronic Stability Program (ESP®)

Electronic Traction System for all-wheel drive (4ETS)

Exterior mirrors with integral indicators and front area lighting, power-adjustable, heated and automatically dimming

Fog lamps with integral cornering light function

Four illuminated door sill panels², illuminated front door sill panels¹

“G-Line” fine wood trim in anthracite³/burr walnut¹/designo²

Headlamp Assist

Headlamp cleaning system

Heated front seats

ISOFIX child seat attachment points⁴

Leather upholstery¹, designo leather upholstery²

Light-alloy wheels – 18-inch for G 500, 16-inch for G 320 CDI

Load retainers in load compartment

Low-range gear reduction (electrically selectable while on the move)

Multifunction steering wheel in leather³, multifunction steering wheel and selector lever in leather/wood^{1,2}

Permanent all-wheel drive with differential

Power-adjustable front seats with memory for seats and exterior mirrors

Power windows

Rain sensor

Seat belts, 3-point design (five) in long Station Wagon

Seat belts, 3-point design (four) in short Station Wagon and Cabriolet

Seat occupancy sensor for front passenger seat

Split-folding rear bench seat (1/2: 1/2) for short Station Wagon and Cabriolet

Split-folding rear bench seat (1/3: 2/3) for long Station Wagon

Steering column power-adjustable, automatic steering wheel adjustment to facilitate entry/exit

THERMATIC automatic climate control

Trailer socket, 13-pin

¹ Standard specification for G 500

² Standard specification for G 55 AMG

³ Standard specification for G 320 CDI

⁴ Only for long Station Wagon



Leaves its mark where only few dare to tread

Reassuring: wheels with tyre pressure monitoring system

As well as transferring lateral forces, driving power and braking power to the road, the G-Class wheels also have to perform when there are no roads at all.

The long Station Wagon is available with an integral tyre pressure monitoring system as an optional extra. The electronic system checks the tyre pressure constantly whilst driving and immediately informs the driver of any pressure loss.

Reveal a new side of your G-Class

The stylish light-alloy wheels for the G-Class

We can't reinvent the wheel. But that doesn't stop us from improving upon it. Our selection of light-alloy wheels is designed to further boost the appeal of your G-Class.

The standard light-alloy wheels feature dynamic 5-spoke styling and are available in 16-inch guise (G 320 CDI) or 18-inch format

(G 500). 18-inch 6-spoke light-alloy wheels are available as optional extras for these models.

The 18-inch light-alloy wheels painted in titanium grey are exclusively available for the G 55 AMG. Their striking design is the ideal match for this powerful variant and exudes stylishness from top to bottom.

16-inch light-alloy wheel (standard for G 320 CDI)



18-inch light-alloy wheel (standard for G 500)



18-inch light-alloy wheel (optional extra for G 320/G 500)



The G-Class carries on long after others have stopped

The optional extras

Although the G-Class comes with an extensive package of standard equipment, it goes one step further by offering an equally wide range of optional extras.

By way of example, the reversing camera attached at the rear in combination with the COMAND APS control and display system and the ultrasonic reversing aid. The reversing camera not only proves its worth when parking but also when manoeuvring on terrain which might have a few surprises in store for you.

The latest-generation COMAND APS control and display system does a lot more than just display the reversing camera's images. You can also employ it to control all the audio, telematics and telecommunications functions via an easy-to-use interface. For example, the navigation system with compass function or your entertainment programme, including MP3 files as well as radio and DVD.

COMAND APS





Comfortable seats for an even better driving feel

The multicontour seat in the G-Class

The G-Class with heated multicontour seat provides an outstanding level of comfort which is sure to be appreciated on long as well as short trips.

The multicontour seat has optimal, ergonomic contouring and is individually adjustable for hardness. Several air chambers under the upholstery material allow you to adjust the multicontour seat precisely according to your own preferences. The chambers in the lumbar area, backrest side bolsters and front seat cushion can be inflated to provide you with excellent stability and lateral support on every trip.

Side stowage box



Side-facing bench seat





OPTIONAL EXTRAS (SELECTION)	CABRIOLET Wheelbase 2400		STATION WAGON SHORT Wheelbase 2400		STATION WAGON LONG Wheelbase 2850		
	G 320 CDI	G 500	G 320 CDI	G 500	G 320 CDI	G 500	G 55 AMG
Anti-theft alarm system	●	●	●	●	●	●	●
ARTICO man-made leather	●	○	●	○	●	○	–
Bumpers painted in body colour	●	□	●	□	●	□	□
Load retaining net	–	–	●	●	●	●	●
CD changer (6-disc) in load compartment	●	●	●	●	●	●	●
Cup holders front and rear	–	–	–	–	○	○	○
Front multicontour seats	● ¹	●	● ¹	●	● ¹	●	●
Garage door opener integrated in interior mirror	●	●	●	●	●	●	●
Heated steering wheel	●	●	●	●	●	●	●
Heavily tinted rear and load-compartment side windows including rear door	–	–	–	–	●	●	●
Pre-installation for mobile phone with interface ²	●	●	●	●	●	●	●
Reversing camera ³	–	–	●	●	●	●	●

¹ Only in conjunction with leather upholstery, Code VS 3/VS 4 or VS 6

³ Only in conjunction with “COMAND APS”, Code ET 4, and ultrasonic reversing aid, Code J 44

² The matching mobile phone cradle (various makes) is available from the Mercedes-Benz accessories range

Cup holders



Ultrasonic reversing aid



OPTIONAL EXTRAS (SELECTION)	CABRIOLET Wheelbase 2400		STATION WAGON SHORT Wheelbase 2400		STATION WAGON LONG Wheelbase 2850			
	G-320 CDI	G-500	G-320 CDI	G-500	G-320 CDI	G-500	G-55 AMG	
Running boards left and right in stainless steel	●	●	●	●		●	●	□
Side-facing bench seat, right (one side) and/or left ⁴	-	-	-	-		●	●	●
Sound system, harman/kardon	-	-	-	-		●	●	●
Spare wheel cover (stainless steel)	●	●	●	●		●	●	□
Sports exhaust system	-	-	-	-		-	●	-
Tilting/sliding sunroof, electric	-	-	●	●		●	●	●
Trailer coupling with ball-type head	●	●	●	●		●	●	●
TV tuner (for analogue/digital reception) ⁵	-	-	●	●		●	●	●
Tyre pressure monitoring system	-	-	-	-		●	●	●
Ultrasonic reversing aid	●	●	●	●		●	●	●

● Available at extra cost □ Standard equipment ○ Available as an option at no extra cost - Not available

⁴Not in conjunction with luggage cover, Code V 57

⁵Only in conjunction with "COMAND APS" control and display system, Code ET 4

Tyre pressure monitoring system







Irresistibly attractive. And remarkably resistant

Clearcoat with greater scratch resistance

1934. The first “Silver Arrow” is probably the only Mercedes-Benz ever to have started out in life with less-than-perfect paintwork. When the Mercedes-Benz engineers put the newly developed W 25 racing car on the scales during scrutineering before the Eifel Grand Prix at the Nürburgring in 1934, the 300-hp car turned out to weigh 751 kilograms – just one kilogram over the strict weight limit imposed by the international racing federation. “Well, that takes the shine off things,” mused Mercedes racing manager Alfred Neubauer – then realised he’d just put his finger on the solution. He promptly ordered the engineers to sand down the white paintwork, thus exposing the silver-coloured aluminium bodywork. This shed the necessary weight and the rest is history: Manfred von Brauchitsch won the race and it wasn’t long before the press were raving about the “Silver Arrows”, as they quickly dubbed them.

2007. Of course, things wouldn’t have been so easy for the team if their car had been sporting today’s latest paintwork developed by Mercedes-Benz. This newly developed clearcoat is significantly tougher than previous clearcoats and is characterised by a more durable sheen which is noticeably more intense. Both metallic and non-metallic paint finishes benefit from the greater scratch resistance of this clearcoat which makes them less susceptible to the effects of the weather and environmental conditions such as precipitation, sunlight, temperature variations, dust and soot.

NON-METALLIC PAINT

The range of paint colours available for the G-Class is so wide that you can choose from five different shades of black alone.



040 black



650 calcite white

METALLIC PAINT¹



112 chromite black



197 obsidian black



300 periclase green



349 lasurite blue



359 tanzanite blue



368 flint grey



541 thulite red



723 cubanite silver



775 iridium silver



798 sanidine beige

designo PAINT



029 designo silver



041 designo graphite



032 designo mystic blue



046 designo platinum black



033 designo mocha black



037 designo mystic red



039 designo mauritius blue

¹ Standard specification for G 500 and G 55 AMG



Who said adventures couldn't be luxurious?

The leather appointments for the G-Class

Leather is an elegant, natural material that is durable and easy to look after. It is ideal for everyday use or on long trips. Best of all, it has an attractive look and a soft feel. There is a choice of leather appointments in black, grey or cognac (optional for the G 320 CDI and standard for the G 500). But whichever one you choose, having an interior design in leather will clearly emphasise the exclusivity of your G-Class.

designo leather appointments, standard for the G 55 AMG, lend your G-Class a sumptuous charm. The seats, head restraints, interior panelling and ruffled pockets are available in ten different shades from the designo range.

grey leather



cognac leather

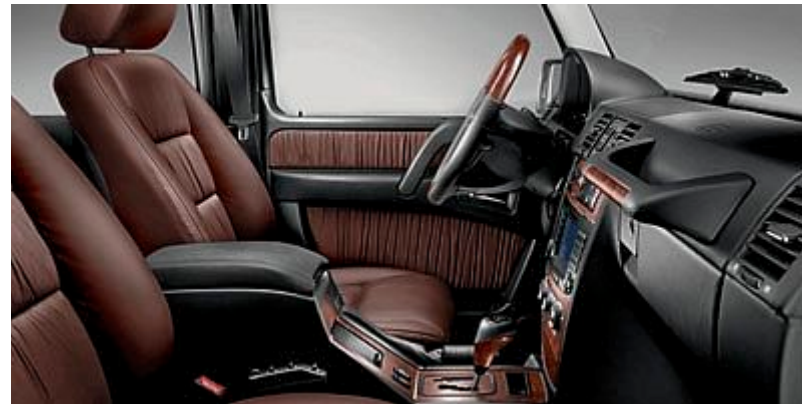



Where robustness meets elegance

The select fabric range

The G 320 CDI features the tried-and-trusted, high-quality fabric coverings in grey and black as standard. Woven from selected textiles, they are just as good a match for the interior design of the G-Class as their leather counterparts.

The ARTICO interior package gives you an extremely hardwearing material for the seats and door side panelling. ARTICO man-made leather proves how elegant robustness can be.

grey fabric



black fabric



FABRIC¹



black



grey

ARTICO man-made leather²



black

LEATHER^{3,4}

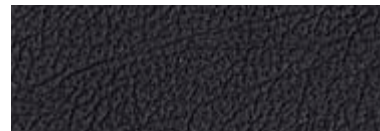

black



grey



cognac

designo LEATHER^{2,5}



ZF2 designo corteccia



ZH2 designo light brown



ZF4 designo marron



ZK8 designo mystic red

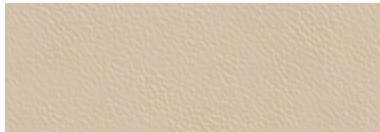

ZF3 designo porcelain



ZJ5 designo chablis



ZK6 designo sand



ZL1 designo mauritius blue

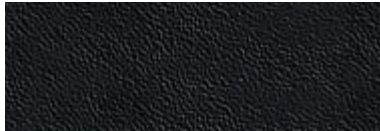

ZH1 designo anthracite

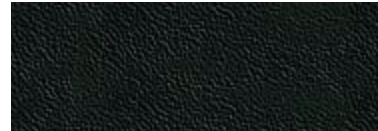

ZK7 designo graphite green

¹ Standard specification for G 320 CDI

² Optional extra for G 320 CDI and G 500

³ Standard specification for G 500

⁴ Optional extra for G 320 CDI

⁵ Standard specification for G 55 AMG

Back to nature

The wood trim elements for the G-Class

The wood trim brings a further aspect of nature into your G-Class. Trim elements in “GLine” anthracite in the G 320 CDI, burr walnut wood in the G 500 or designo fine wood in the G 55 AMG lend the interior an exclusive ambience.

The meticulous crafting of the wood gives the surface an extremely pleasant feel. In combination with the leather appointments, the wood trim elements create a truly harmonious interplay of natural materials.

WOOD

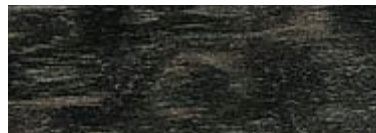

“G-Line” anthracite¹



Burr walnut^{2,3}

designo TRIM ELEMENTS



ZG0 designo matt red-brown cinnamora^{4,5}



ZM0 designo natural maple grain^{4,5}



ZM5 designo natural poplar^{4,5}



ZM7 designo anthracite poplar^{4,5}

¹ Standard specification for G 320 CDI

² Standard specification for G 500

³ Optional extra for G 320 CDI

⁴ Optional extra for G 320 CDI and G 500

⁵ Standard specification for G 55 AMG

	<i>G-320 CDI Fabric standard</i>		<i>G-320 CDI Leather optional extra</i>			<i>G-500 Leather standard</i>	
	black	grey	black	grey	cognac	black	grey

NON-METALLIC PAINT

calcite white	●	●	●	●	●	△	△
black	●	●	●	●	●	△	△

METALLIC PAINT

chromite black	●	●	●	●	●	●	●
obsidian black	●	●	●	●	●	●	●
periclase green	●	●	●	●	○	●	●
lasurite blue	●	●	●	●	○	●	●
tanzanite blue	●	●	●	●	●	●	●
flint grey	●	●	●	●	○	●	●
thulite red	●	●	●	●	○	●	●
cubanite silver	●	○	●	○	●	●	○
iridium silver	●	●	●	●	●	●	●
sanidine beige	●	○	●	○	●	●	○

● Recommended ○ Possible △ Not possible

	<i>G 320 CDI</i>		<i>G 500</i>		<i>G 55 AMG</i>
No. of cylinders/arrangement	6/V		8/V		8/V
Bore/stroke (mm)	83.0/92.0		97.0/84.0		97.0/92.0
Total displacement (cc)	2987		4966		5439
Rated output (kW at rpm) ¹	165/3800		218/5500		368/6100
Rated torque (Nm at rpm) ¹	540/1600-2400		456/2800-4000		700/2750-4000
Top speed, approx (km/h)	177		190		210 ²
Tyre size	265/70 R 16		265/60 R 18		285/55 R 18
Fuel consumption (l/100km) ³ urban/extra-urban/combined	Diesel 13.4/9.7/11.0		Premium 20.6/12.5/15.5		Premium 21.4/12.7/15.9
Tank capacity (l)/incl approx. reserve	96		96		96
CO ₂ emissions (g/km) ³ combined	302		370		378
	<i>Cabriolet</i>	<i>Station Wagon short/long</i>	<i>Cabriolet</i>	<i>Station Wagon short/long</i>	<i>Station Wagon long</i>
Acceleration 0-100 km/h (s)	8.8	8.8/9.1	7.3	7.3/7.5	5.5
Kerb weight (kg) ⁴	2260	2275/2445	2250	2265/2400	2550
Payload (kg)	590	575/755	600	585/800	650
Permissible GVW (kg)	2850	2850/3200	2850	2850/3200	3200
Trailer load (unbraked) (kg)	750	750/750	750	750/750	750
Trailer load (braked) incl. drawbar load (kg)					
115 kg short wheelbase	2850 ⁵	2850 ⁵ /-	2850 ⁵	2850 ⁵ /-	-
140 kg long wheelbase	-	-/3500 ⁶	-	-/3500 ⁶	3500 ⁶
Gross combination weight (kg)	5700	5700/6700	5700	5700/6560	6560

¹ Figures according to Directive 80/1269/EEC in the currently applicable version

² Electronically governed

³ The figures shown were obtained in accordance with the prescribed measuring process (Directive 80/1268/EEC in the currently applicable version). The figures are based on an individual model and do not constitute part of the product offer; they are provided solely for purposes of comparison between different vehicle models

⁴ Figures according to Directive 1992/21/EC, as amended by 1995/48/EC (kerb weight with fuel tank 90 % full, driver, 68 kg, and luggage, 7 kg) for standard-specification vehicles. Optional extras and accessories will generally increase this figure and reduce the payload capacity accordingly

⁵ Statutory requirements met for 12 % gradient at 2850 kg

⁶ Statutory requirements met for 12 % gradient at 3500 kg

The G-Class

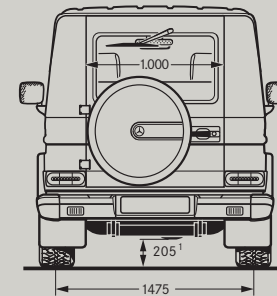
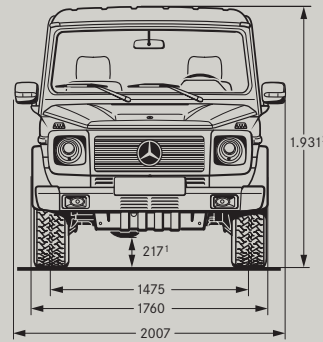
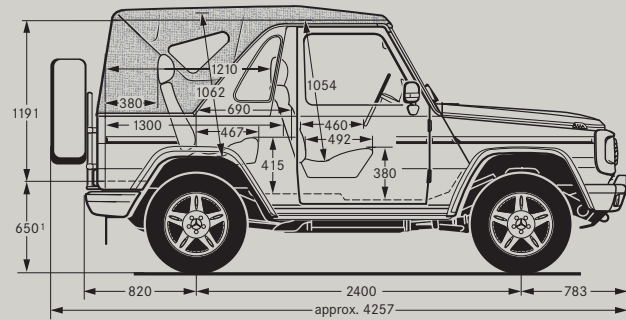
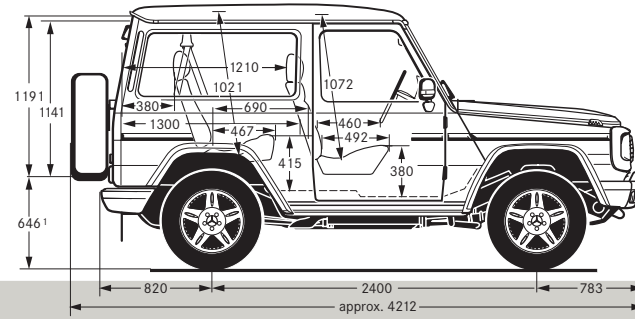
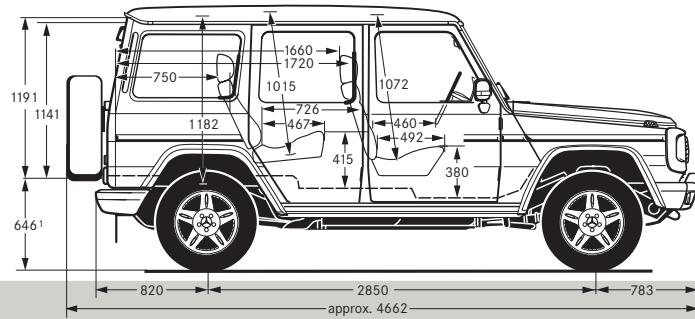

The dimensions shown are mean values (in mm) and apply to standard-specification vehicles carrying three occupants weighing 68 kg each

¹With maximum permissible payload

²Height of Cabriolet: 1941 mm

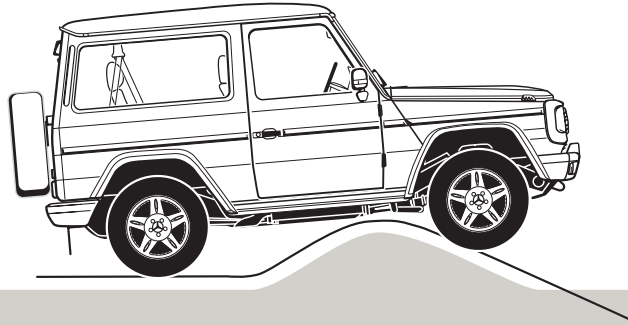

Large ramp angle

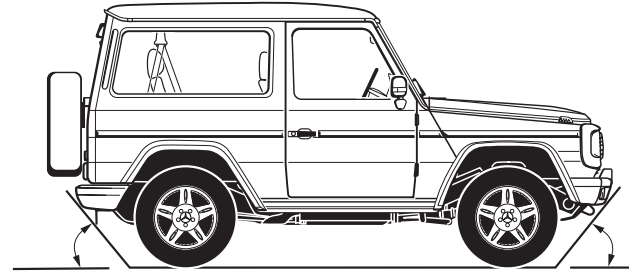

Angle of approach 36° / departure 27°

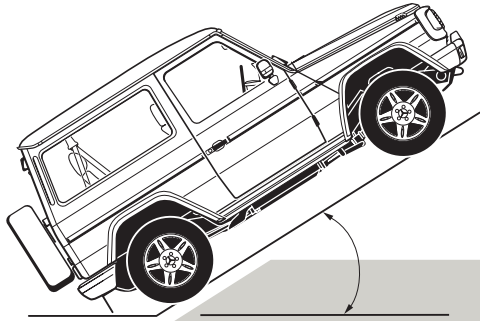

Slope-climbing ability up to 80%, depending on terrain



Ground clearance 21 cm

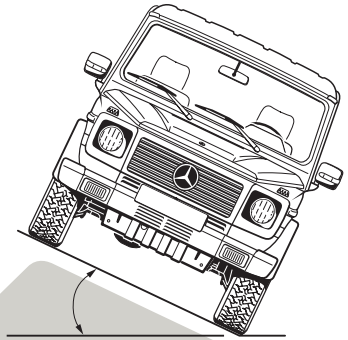

Directionally stable on lateral slopes up to 54%

The best places to go star-gazing

The world of Mercedes-Benz: our centres, dealerships, the museum and the MercedesCard

Mercedes-Benz Centres

It all started in Berlin at the end of 2000: the concept of the car dealership was reinvented with the opening of the first Mercedes-Benz Centre. Featuring the entire Mercedes-Benz model line-up as well as the accessories range, brand merchandise and an attractive programme of events, the Centres offer a welcoming environment in which to experience the brand at first hand.

And even when you're not in a large city, you are never far from the wide range of services, the comprehensive customer care and the high quality which you expect from Mercedes-Benz. A close-knit network of company branches and authorised dealers makes sure of that. You can count on their support at every stage – before, during and, most importantly, long after the purchase of your Mercedes.

Mercedes-Benz Museum

More than 120 years of automotive history brought together under one roof – that's the Mercedes-Benz Museum in Untertürkheim, Stuttgart. Waiting to whisk visitors away into a fascinating world are exhibitions covering a total of 16,500 m² of floor space. You can see the very first modern-day car, the Mercedes

Simplex, take a nostalgic look back at over 100 years of motorsport, and, of course, admire our classics, such as the Gullwing and the "Tail Fin". Legendary cars such as these have always occupied a special place in the hearts of car enthusiasts. Now they have a special place of their own in the Mercedes-Benz Museum.

We look forward to welcoming you there soon.



MercedesCard

There's also a wealth of experiences to enjoy when you're not at the wheel of your Mercedes. Owning a MercedesCard is all it takes. Your ticket to the world of Mercedes-Benz also doubles as a practical credit card. Complete the annual survey and we'll even waive the card fee.

In the regular MercedesCard Journal you'll find details of sporting, cultural and travel offers which have been specially selected for you as well as attractive products. The Mercedes Magazine features interesting articles about the Mercedes-Benz brand. Your MercedesCard also gives you free entry to the Mercedes-Benz Museum. In addition to these exciting benefits, the MercedesCard offers you some very reassuring ones, too: you can protect yourself from life's less welcome surprises with Mercedes-Benz travel insurance and the MercedesCard insurance package.

Full details and application forms can be found at www.mercedes-benz.de/mercedescard

Information about the MercedesCard in Austria and Switzerland can be found on the Mercedes-Benz websites for these countries.

Have we convinced you? If you'd like to find out more, there's no substitute for a test drive

Test drive

With the G-Class, as with all our models, it's that unique feeling you get when you actually drive a Mercedes that makes it so special. It's something that's communicated by even the smallest details, such as the feel of the indicator control or the solid, reassuring way the doors close. But a brochure can never do justice to qualities like these, they have to be experienced first-hand in a test drive.

You're cordially invited to do just that. To locate your nearest Mercedes-Benz dealer, visit our website at www.mercedes-benz.com. Your dealer will be happy to arrange an appointment.

Interactive Owner's Manual

Our website features informational clips and simulations designed to help you familiarise yourself with the various functions of the vehicle. You can learn about its equipment and how to operate it and get a clear picture of a selection of the features inside that make driving a Mercedes such a pleasure.

For further details, go to:
www.mercedes-benz.de/betriebsanleitung

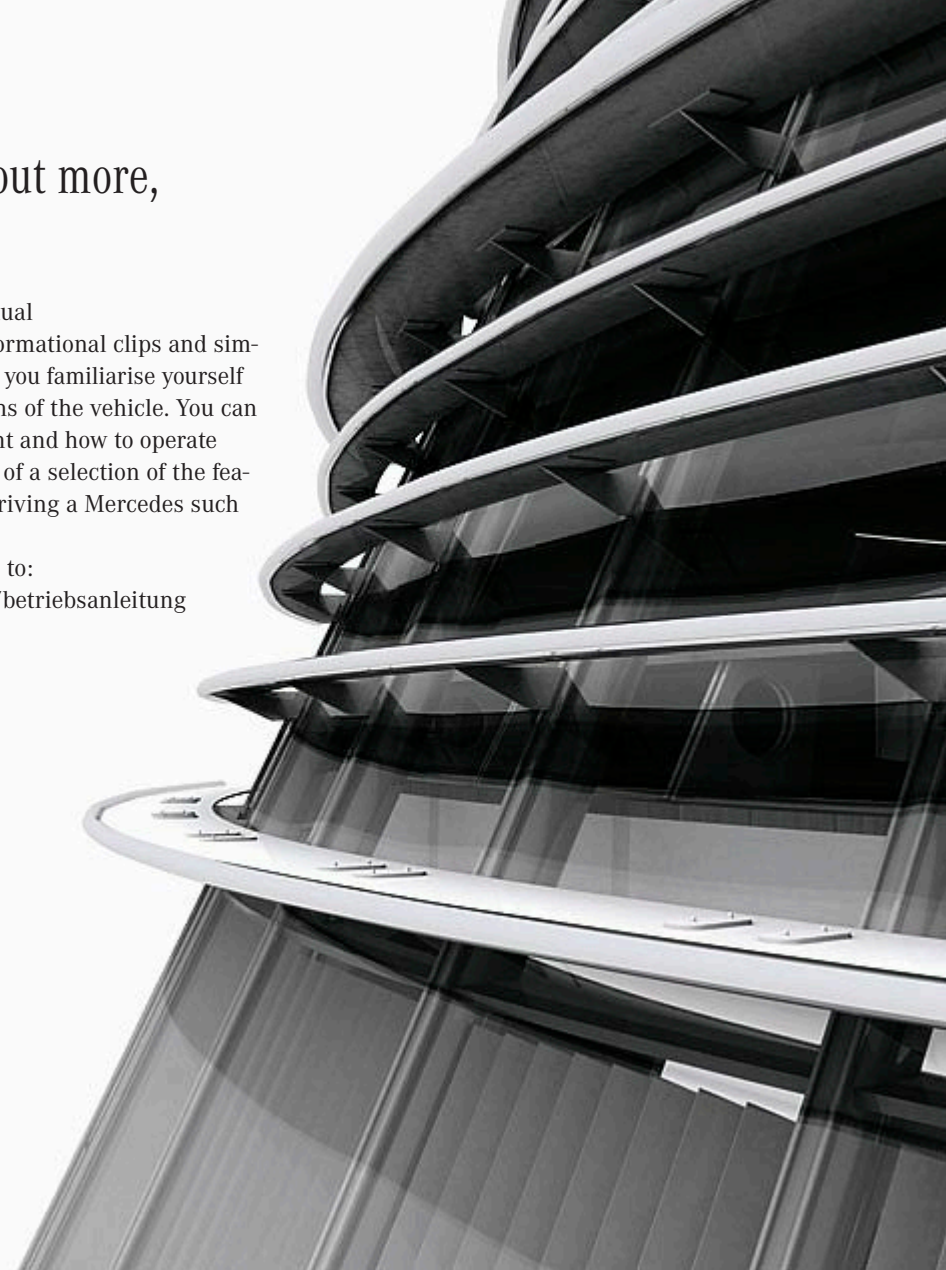

Owning a Mercedes is even more reassuring than you might think

Service24h and the financial services offered by DaimlerChrysler Bank

Service24h

All it takes is a call to Mercedes-Benz on 00800 1 777 7777 from almost any European landline or mobile phone network, and our Service24h will be able to assist you in your own language. It is available 24 hours a day, 365 days a year.

DaimlerChrysler Bank

If you have already set your heart on your dream Mercedes and want to remain flexible in financial terms, our financial services can turn your dream into reality. Whether you are looking for leasing, financing, insurance or service packages, we can provide them all. The online calculator makes it easy for you to work out your monthly payments.

In addition to individually geared financial services, we can also offer you attractive investment products, such as a call account, fixed-income investments or portfolio funds.

More information is available by phone on 0 18 03-DC BANK or 0 18 03-32 2265 (calls charged at 9 euro cents per minute) or by visiting www.daimlerchrysler-bank.de

Take-back of end-of-life vehicles. Coming full circle

At the end of its long life, you can return your G-Class to us for environment-friendly disposal in accordance with the EC End-Of-Life Vehicle Directive¹. But that day lies a long way off.

¹ Applies in accordance with national regulations to vehicles up to 3.5 tonnes permissible gross weight. Mercedes-Benz passenger cars have met the statutory regulations governing the suitability of their design for reuse and recycling for a number of years now. A network of vehicle take-back depots and dismantlers has been established which will process your vehicle in an environment-friendly manner. The ways in which both vehicles and parts can be recovered are subject to ongoing development and improvement. Consequently, the G-Class will be able to comply with any future increases in the recycling quota within the stipulated time limits. For further information, please go to www.mercedes-benz.de or call 00800 1 777 7777.

Please note: changes may have been made to the products since this brochure went to press (31.05.2007). The manufacturer reserves the right to make changes to the design, form, colour and specification during the delivery period, provided these changes, while taking into account the interests of the vendor, can be deemed reasonable with respect to the purchaser. Where the vendor or the manufacturer uses symbols or numbers to describe an order or the subject of an order, no rights may be derived solely from these. The illustrations may show accessories and items of optional equipment which are not part of standard specification. Colours may differ slightly from those shown in the brochure, owing to the limitations of the printing process. This brochure has been compiled by DaimlerChrysler AG of Germany and is distributed internationally. It provides a general indication of the range of models, features, optional extras and/or colours available in various countries. Some of the models, features, optional extras and/or colours shown may not be available in your country or may only be available in a different specification. Additionally some models, features, optional extras and/or colours may only be available in combination with others. For current and more specific information in relation to the range of models, features, optional extras and/or colours available in your country, and their pricing, you should contact your nearest authorised Mercedes-Benz Passenger Car Dealer.